

# GREEN SOLUTIONS

SYSTEMS FOR THE MANAGEMENT OF LANDSCAPES AND NURSERIES

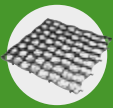

**RUNFLOOR**

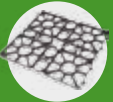

**GEOFLOR**



**GEOGRASS**

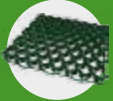

**SALVAVERDE**

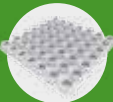

**GEOGRAVEL**

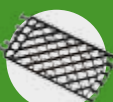

**GEOROAD**



**DRAINROOF**



**WALL-Y**



**PLASTONELLA**



**TUBS AND VASES**

✓ **RESISTANCE**

✓ **DURABILITY**

✓ **SUSTAINABILITY**

# INDEX

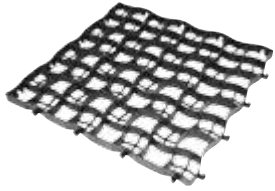

## RUNFLOOR

High-strength plastic grass paver for permeable drivable areas.

**P. 5**



## GEOFLOR

Plastic ground paver for installation above existing lawns.

**P. 14**



## GEOGRASS

Grass reinforcement paving grids.

**P. 21**



## SALVAVERDE

Cellular grass paver for walkable and drivable green areas.

**P. 27**



## GEOGRAVEL

Gravel stabilizer grid for driveways and car parks.

**P. 33**



## GEOROAD

Plastic ground paver for reinforcement of road verges.

**P. 40**





## DRAINROOF

High-performance green roof drainage board.

**P. 46**



## WALL-Y

Modular element for green walls.

**P. 58**

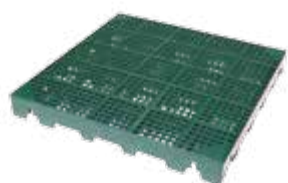

## PLASTONELLA

Modular self-install plastic paver for outdoors.

**P. 64**



## TUBS AND VASES

Heavy duty pots, tubs and rainwater harvesting tanks for nurseries.

**P. 67**



## FOR INFO AND ASSISTANCE CONTACT US

### GEOPLAST

Tel +39 049 9490289 - Fax +39 049 9494028 - info@geoplast.it

### AREA MANAGERS FOR ITALY

Verde@Geoplast.it

### EXPORT AREA MANAGERS

Export@Geoplast.it

To consult the support material, the images and the new case studies, visit our website:

**Geoplast.it**



# GREEN ADVANTAGES



Solutions to protect the grass and create green or gravel transitable turfs, roof gardens and green walls.

## PERMEABILITY

Geoplast respects the urban constraints that want a correct disposal of rainwater respecting the hydrological balance.

## BEAUTY

The particular texture of the trellis guarantees beauty and elegance to the wall even before the growth of the vegetation.

## THERMAL INSULATION

GEOPLAST systems can reduce both cementification in the cities and thermal insulation.

## RESISTANCE

The structure and material of our systems provide to GEOPLAST material a high strength and resistance.

## DURABILITY

The structure and the material characteristics guarantee a safe and longlasting result.

## DRAINAGE AND SUSTAINABILITY

GEOPLAST systems guarantee and excellent rainwater drainage and permit a beneficial long-lasting effect of the nature.



# RUNFLOOR



**HIGH-STRENGTH PLASTIC GRASS PAVER FOR PERMEABLE DRIVABLE AREAS**

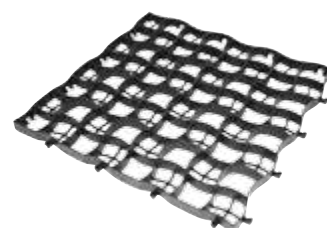

# RUNFLOOR THE SOLUTION



RUNFLOOR is the solution for the creation of grass and gravel permeable and highly resistant car parks. Thanks to its reinforced structure, RUNFLOOR is very resistant to the typical stress produced by vehicles in motion, such as brakings and steers, also in case of heavy trucks, and provides durability to the parking. The particular shape of the cells and the thickness of the ribbings produce a higher load-bearing capacity compared to traditional systems. Thanks to the elasticity of the material, items in Low Density Polyethylene (LD PE) have better performance even at low temperatures.

**PUBLIC CAR PARKS**

**HIGH TRANSITED CAR PARKS**

**TRANSIT AND STOP OF HEAVY MEANS**

**SUITABLE FOR ANY TYPE OF CLIMATE**





# RUNFLOOR THE RANGE



## F03 - FLEXIBLE



With cells of 3 cm height and reduced thickness RUNFLOOR F03 is the appropriate choice that maintains technical resistance unchanged.

## F04 - AVERAGE



RUNFLOOR F04 is 4 cm high and complies with the dimensional requirements of the traditional drivable grids. It guarantees stability and robustness, necessary in every type of car park.

## F05 - UNIVERSAL



RUNFLOOR F05 is the result of perfect combination between performance and quality. Excellent in high trafficked areas, it ensures a perfect and safe drivability.

## S05 - STRONG



It's the top of the range: compact and robust, RUNFLOOR S05 is characterized by a thickening of the internal ribbings between cells. Ideal in surfaces with intense traffic as car parks and public transit areas.



# RUNFLOOR TECHNICAL DATA

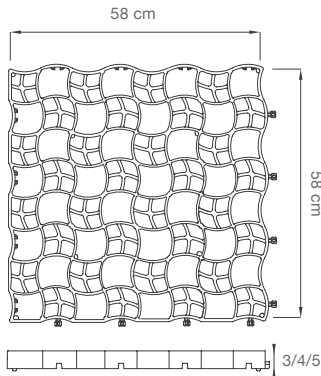

## RUNFLOOR 58\* (LD PE)

\*Available also in HD PE and in green



**RUNFLOOR  
58-F03**



**RUNFLOOR  
58-F04**



**RUNFLOOR  
58-F05**

SIZE (cm)	58 x 58	58 x 58	58 x 58
HEIGHT H (cm)	3	4	5
Wall thickness (mm)	4	4	4
Load capacity (t/m <sup>2</sup> )	400	400	500
Weight per pc. (kg)	1.22	1.75	2.16
Packaging size (cm)	120 x 120 x 235	120 x 120 x 242	120 x 120 x 235
No. pcs.	300	228	180
m <sup>2</sup> per pallets	100	76	60
Color	Black	Black	Black
Permeability	89%	89%	89%

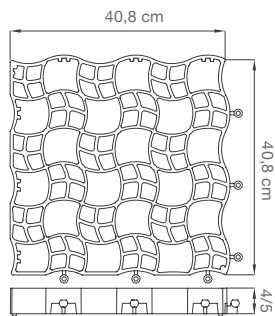

## RUNFLOOR 40 (LD PE)



**RUNFLOOR  
40-F04**



**RUNFLOOR  
40-F05**



**RUNFLOOR  
40-S05**

SIZE (cm)	40,8 x 40,8	40,8 x 40,8	40,8 x 40,8
HEIGHT H (cm)	4	5	5
Wall thickness (mm)	4	4	5
Load capacity (t/m <sup>2</sup> )	400	500	600
Weight per pc. (kg)	0,76	0,90	1,27
Packaging size (cm)	85 x 125 x 220	85 x 125 x 235	85 x 125 x 235
No. pcs.	300	270	270
m <sup>2</sup> per pallet	50	45	45
Color	Black	Black	Black
Permeability	84%	84%	83%

## ACCESSORY CAP



MATERIAL PP

COLOR

White ○

Yellow ●

With flagging caps it is possible to signalise car park boundaries, reserved areas, pedestrian paths, etc. It is equipped with a nonslip surface and a peg for ground anchorage.

# AN INNOVATIVE LOCKING SYSTEM



The innovative twist-lock system (male/female) simplifies the installation and guarantees the perfect connection of the paving grids. The characteristic “Click” makes the job easier indicating that the connection has been successful. It is possible and recommended to pre assemble the grid elements before placing it, in order to speed installation. RUNFLOOR locking system allows a close connection between the elements, reducing the worker’s movements during the installation and filling operations and preventing unwanted liftings of any item.

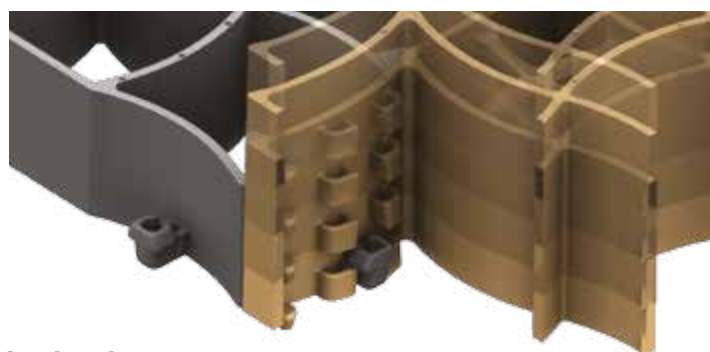

**ESTIMATED TIME OF INSTALLATION - 100 M<sup>2</sup> / H/ WORKER**

## RUNFLOOR STRATIGRAPHY

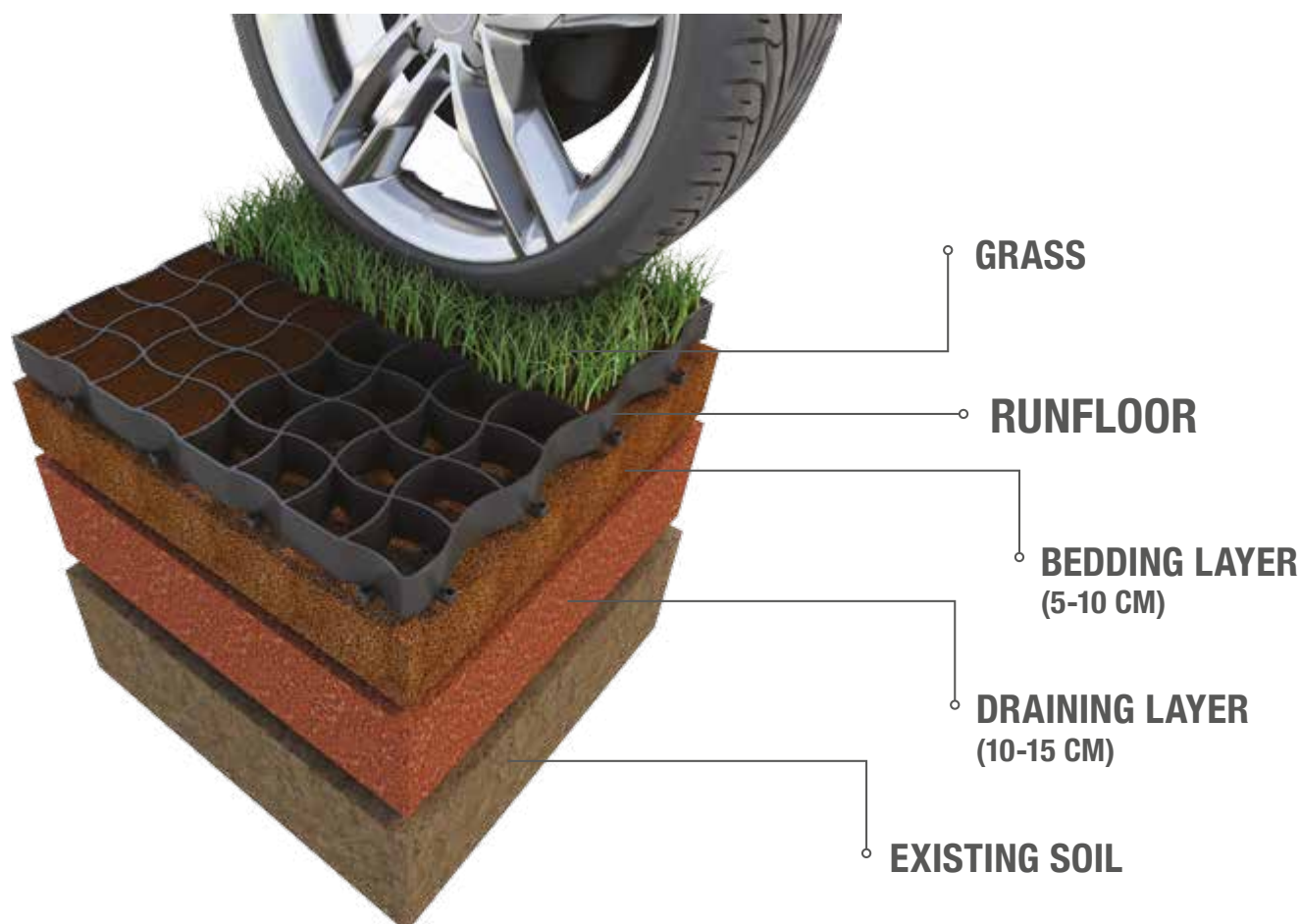

# INSTALLATION

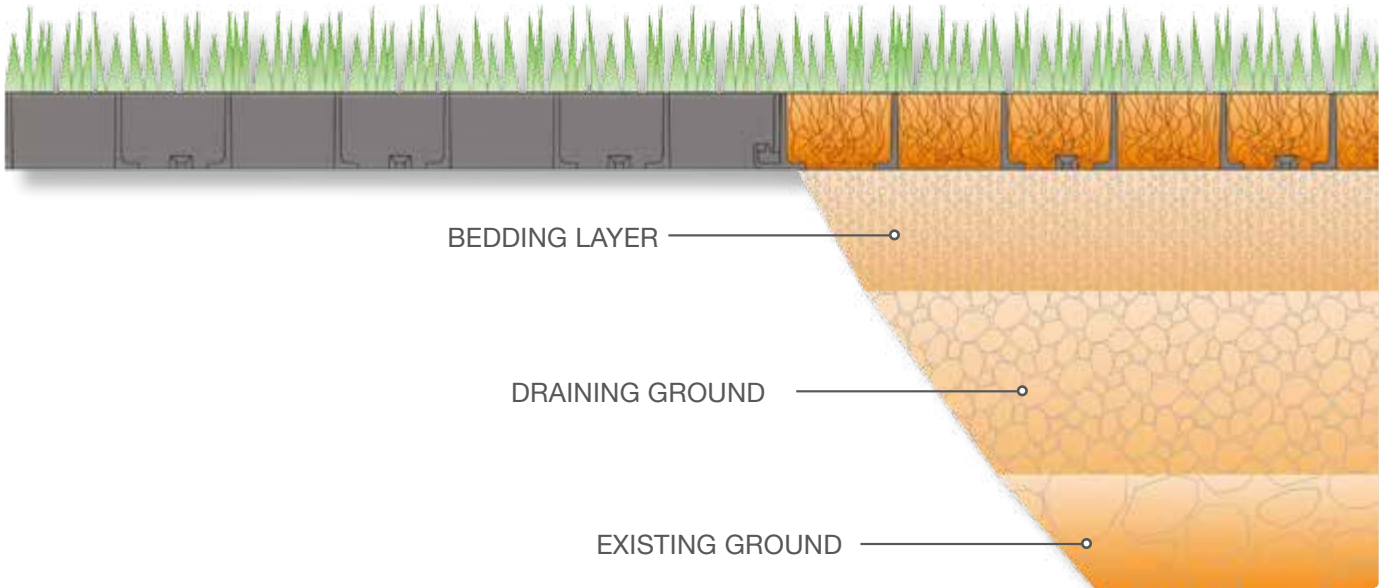

**① PERMEABLE SUB-BASE 10 - 15 cm**  
Permeable sub-base of 10-15 cm with volcanic lapilli (granulometry 5-20 mm) with high water retention capacity and crush resistance 35 N/mm<sup>2</sup> (UNI 754917). This thickness can vary from 8/10 cm for walkable loads and 30/40 cm for trucks and commercial means.



**② BEDDING LAYER 5 - 10 cm**  
Well compacted and levelled bedding layer of 10-15 cm with a mixture of volcanic sands enriched with vegetal soil and organic fertilizers (granulometry 0-5 mm)



**③ INSTALLATION**  
Runfloor guarantees the drainage of rainwater and the protection of the roll turf, but also prevents the crushing of the roots from the transit of vehicles.



**④ FILLING WITH SANDS**  
Filling of the cells with a mixture of volcanic sands, enriched with compost and organic fertilisers (granulometry 0-5 mm). In alternative, fill with a mixture of silica sand, enriched with peat and humus. For an optimal result, it is recommended an wait 2-3 mows, in order to let the grass grow, before transiting in the area.



**⑤ SEEDING**  
Finishing and seeding.



**⑥ MARKING CAPS**  
Marking caps for the delimitation of car parks, reserved areas, walkways, ecc. It is recommended to use at least 4 caps per linear meter.



# GRID ADVANTAGES AND PRESCRIPTIONS



## ADVANTAGES OF A TRANSITABLE TURF

**TOTAL PERMEABILITY**  
**INCREASING OF GREEN AREAS**  
**ENVIRONMENT MITIGATION**

## WHY THE GRID?

**PROTECTION OF THE GRASS**  
**FURROWS ELIMINATION**  
**HOMOGENEOUS MAINTENANCE OF THE TURF**

## RUNFLOOR PRESCRIPTIONS

- When installing the grids, leave an expansion gap of about 3-5 cm from the curb and any obstacle.
- In the case of large surfaces, it is necessary to square areas of about 30 m<sup>2</sup> leaving expansion gaps, which consist in juxtaposing the grids without hooking them (leaving about a cm of span).
- Design and install a specific irrigation system.
- Perform the finishing and seeding operations respecting the correct seasonality.
- Wait for the complete growth of the grass and two mowings before passing on the surface with vehicles.
- To mow the lawn it is necessary to adjust the mower blades. The same should be done with snowplows.
- Restore any decrease of filling material.
- Carry out periodically the proper maintenance of the lawn, with eventual fertilization and ventilation of the soil.
- RUNFLOOR can be easily shaped with a saw or a grinding disc close to curbs or inspection man-holes.
- The maximum slope for drivable applications is 8%. If superior, use forks and pegs to anchor RUNFLOOR to the ground.



## TURF MAINTENANCE

In order to have a good turf, it would be necessary to carry on these simple maintenance operations:

- IRRIGATION
- REMOVAL OF WEEDS AND INFESTING PLANTS
- MOWING
- FERTILISATION
- REPLANTING OR SEEDING WITHOUT DAMAGING THE GREEN AREA
- MATERIAL ADDITION IN CASE OF LOSS

It is possible to obtain a perfect result over time, keeping the turf protected even with a continue passage of people and vehicles on it.

# PUBLIC AND PRIVATE CAR PARKS

RUNFLOOR is suitable for the creation of any type of drivable surface. It is made of LDPE (Low Density Polyethylene), a plastic material characterized by high flexibility, which makes it resistant even when exposed to the sun, avoiding the crystallization typical of grid elements made of other polymers. For this reason, RUNFLOOR is useful for public parkings or permeable drivable surfaces and suitable for heavy vehicles and any area where there is no need of steady maintenance.



# ACCESS RAMPS FOR BOATS

Thanks to the elasticity of the LDPE of which it is made, RUNFLOOR guarantees maximum resistance to the passage of heavy vehicles, such as lorries and trucks. Installed on a permeable sub-base built with sand or gravel, it allows to create consolidated and comfortable drivable surfaces. Moreover, thanks to the UV-resistant treatment, RUNFLOOR ensures longlasting results.





# CAMPING AREAS

RUNFLOOR is ideal for creating green permeable surfaces for the passage, the transit and the parking of heavy vehicles. RUNFLOOR material and structure guarantee maximum load-bearing capacity and resistance to the typical stresses produced by vehicles, such as brakings and swerves, also in areas characterized by low temperatures, without the risk of crystallization, which is typical of traditional grids. Once the grass has grown, the surface looks like a natural lawn.



# EQUESTRIAN SURFACES

The thickness of the ribbings and the material elasticity make RUNFLOOR the perfect solution for the realization of equestrian surfaces dedicated to training, races, paddocks or carousels, as it ensures the total protection of the tendons and joints of the horse. Furthermore the high permeability of the grid prevents the formation of mud, keeping the surface always dry.





# GEOFLO



**PLASTIC GROUND PAVER FOR INSTALLATION ABOVE EXISTING LAWNS**



# GEOFLORE THE SOLUTION



GEOFLORE is the grid for the creation of any type of walkable turf. It was born from a synergetic project between University and Industry, the perfect summary between technique and agricultural knowledge. Thanks to its large cells, which characterize the grid's geometry and to the flexible and elastic material, GEOFLORE can be installed directly over the existing turf. It can instantly protect the lawn and the roots system allowing the transit of vehicles immediately.

**EXISTING LAWNS**

**SOWN TURFS**

**LAYING TURFS**

**TEMPORARY PROTECTION**





# GEOFLOLOR TECHNICAL DATA

GEOFLOLOR is ideal to transform a turf into a parking lot or into a driveway, without the preparation of a specific subsoil. Furthermore, it can be used for the creation of grass parkings with specific mineral sub-layers. It is also possible to use it as temporary protection of the lawn in case of sporting events, fairs, concerts and general events.



## GEOFLOLOR

Real size (cm)	50 x 50 x H2.4
Material	LD PE
Weight (kg)	1.16
Packaging size (cm)	100 x 112 x H230
No. pcs. per pallet	400
Load capability (ton/m <sup>2</sup> )	100

Modulus of elasticity 780 N/mm<sup>2</sup>  
Tensile break strength 22 N/mm<sup>2</sup>  
Thermal expansion coefficient 0,2 mm/m/°C

## CAPS



### COLOR

- White ○
- Yellow ●

The cap allows the marking of the parking areas, private areas, driveways, ecc. It presents a slip-resistant surface and an anchoring rod to the ground.

## GEOFLOLOR STRATIGRAPHY

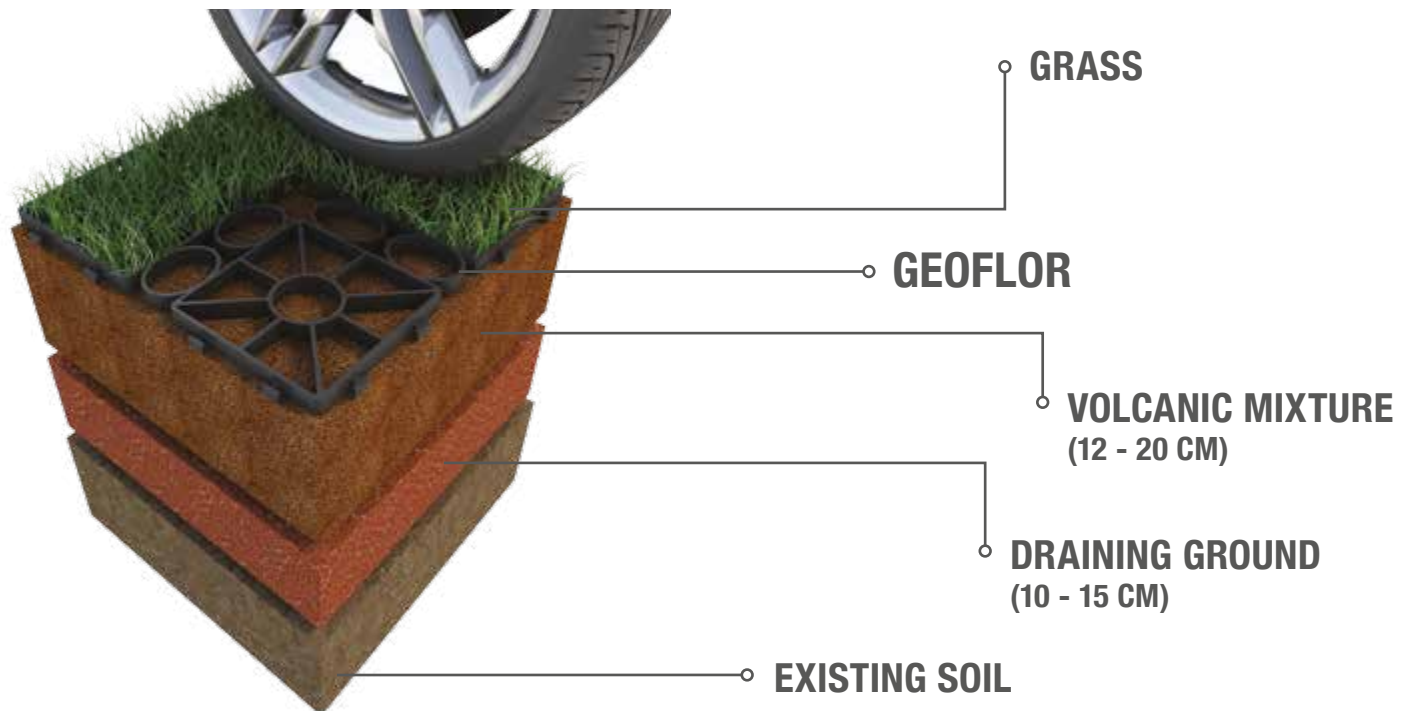



# INSTALLATION

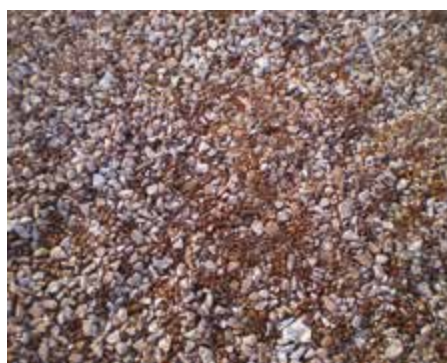
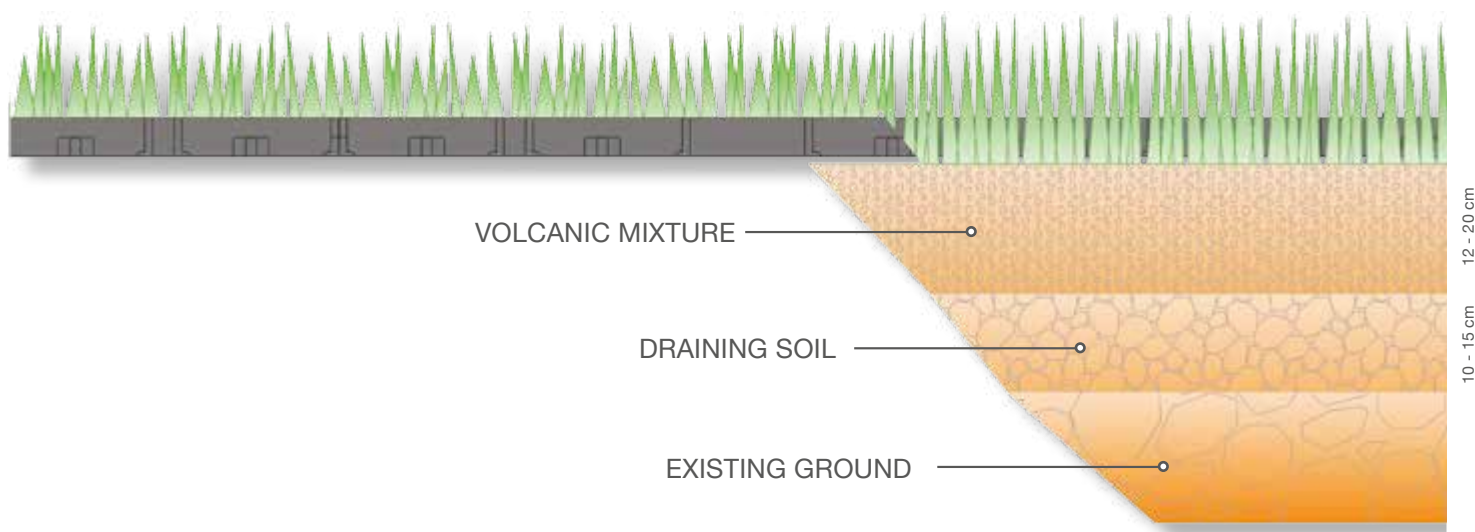

- ① DRAINING SOIL 10 - 15 cm**  
Prepare a 10-15 cm thick drainage layer of gravel volcanic lapillus, grain size 5-20 mm.



- ② SAND BEDDING**  
Create a 20 cm thick mixture of volcanic sands, grain size 0 - 12 mm (with an existing turf, improvement of the soil through a layer of sand of 8 - 10 cm).



- ③ TURF LAYING (OR SEEDING)**  
Place the sown laying turf, or alternatively seed the grass.



- ④ INSTALLATION OF PRE-ASSEMBLED GEOFLOR**  
GEOFLOR installation through the pre-assembly of the grid.

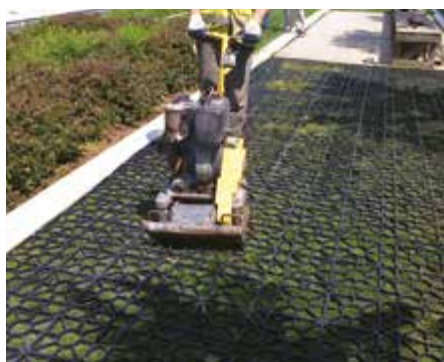

- ⑤ PRIOR IRRIGATION, LAY THE PRODUCT MANUALLY**  
Roll in the presence of an existing or laying turf, if the turf has already been seed, the operation is not necessary.



- ⑥ GEOFLOR - FINAL RESULT**  
Cut the grass 2 - 3 times in 15 - 20 days, until GEOFLOR is partially incorporated with the sub-layer.

# GRID ADVANTAGES AND PRESCRIPTIONS



## ADVANTAGES OF A TRANSITABLE TURF

- TOTAL PERMEABILITY**
- INCREASE OF THE GREEN AREAS**
- ENVIRONMENT MITIGATION**

## WHY GEOFLOR ?

- AVOIDS THE SUB-LAYER COMPRESSION**
- LOW MAINTENANCE OF THE TURF**
- CONSERVATION OF THE LAWN AND RESULT GUARANTEED**

## GEOFLOR PRESCRIPTIONS

- During the grids installation, keep the expansion joint at a distance of 3-5 cm away from the kerbs and any other obstacle.
- In case of large surfaces, it is recommended to frame an area of 30 m<sup>2</sup> providing the grids with expansion joints, without hooking them but just putting put them closer instead, (leaving a span of about 1 cm).
- Design and provide a specific irrigation system.
- The finishing and seeding have to respect the right seasonality.
- Wait for the complete grassing before transiting over the area.
- To cut the turf, the regulation of the lawnmower blade is sufficient. It can similarly be made with snowploughs.
- GEOFLOR can be removed at a later time to ventilate the turf and carry the specific treatments.
- Restore the possible losses of filling material.

- Periodically carry out the right maintenance of the turf and possible fertilisation.
- GEOFLOR can be easily shaped with a saw or a grinding machine in close proximity of kerbs and manholes.
- The required maximal slope for transitable applications is of 8%. When it is higher, use forks or stakes to fasten GEOFLOR to the soil.



## TURF MAINTENANCE

In order to have a good turf, it is recommended to follow these common maintenance operations:

- IRRIGATION
- WEEDS AND INFESTING PLANTS REMOVAL
- MOWING
- FERTILISATION
- REPLANTING OR SEEDING WHERE THE GREEN AREA MAY SUFFER DAMAGES
- ADD MATERIAL IN CASE OF DECLINE

It is possible to obtain a perfect result over time, keeping the lawn protected even with the transit of people and vehicles on it.



# EXISTING TURF

GEOFLORE is ideal when the turf already exists and it is well consolidated. Through small processes (ground levellings, adding of volcanic sands for a fast consolidation, etc.), it is possible to make the turf transitable and walkable, even in great artistic value areas: the grid does not have any impact on the functional and aesthetic appeal. GEOFLORE grid assured a positive feedback in a worldrenowned location where it was not possible to make mistakes.



# SOWN TURF

Differently from the traditional methods, GEOFLORE can be placed on a sown and finished turf, when the grass seeding is complete. The grid is installed when the grass is cut for the first time and after a few days it will be completely incorporated into the grass. The result is always perfect, because GEOFLORE large holes and base allow the grass to fill the gaps quickly without any damage.





# LAYING TURF

The main application of GEOFLOR is the installation on a laying turf. The parking areas are created at the end of the surrounding buildings construction or at the end of the main processes: usually it is hard to respect the ending-times of the works in the construction site. The winning solution, in order to speed up the phases, is the combined installation of both GEOFLOR and the laying turf.



# TEMPORARY PROTECTION OF THE TURF

GEOFLOR strength and flexibility allow the grid to adapt to any surface and become transitable and usable for transitional periods, protecting the roots from crushing forces. If the grid remains installed for a longer period of time, it is still possible to remove it to restore the turf or to carry specific treatments, like ventilation or soil levelling. The result will be a perfectly transitable turf.





# GEOGRASS

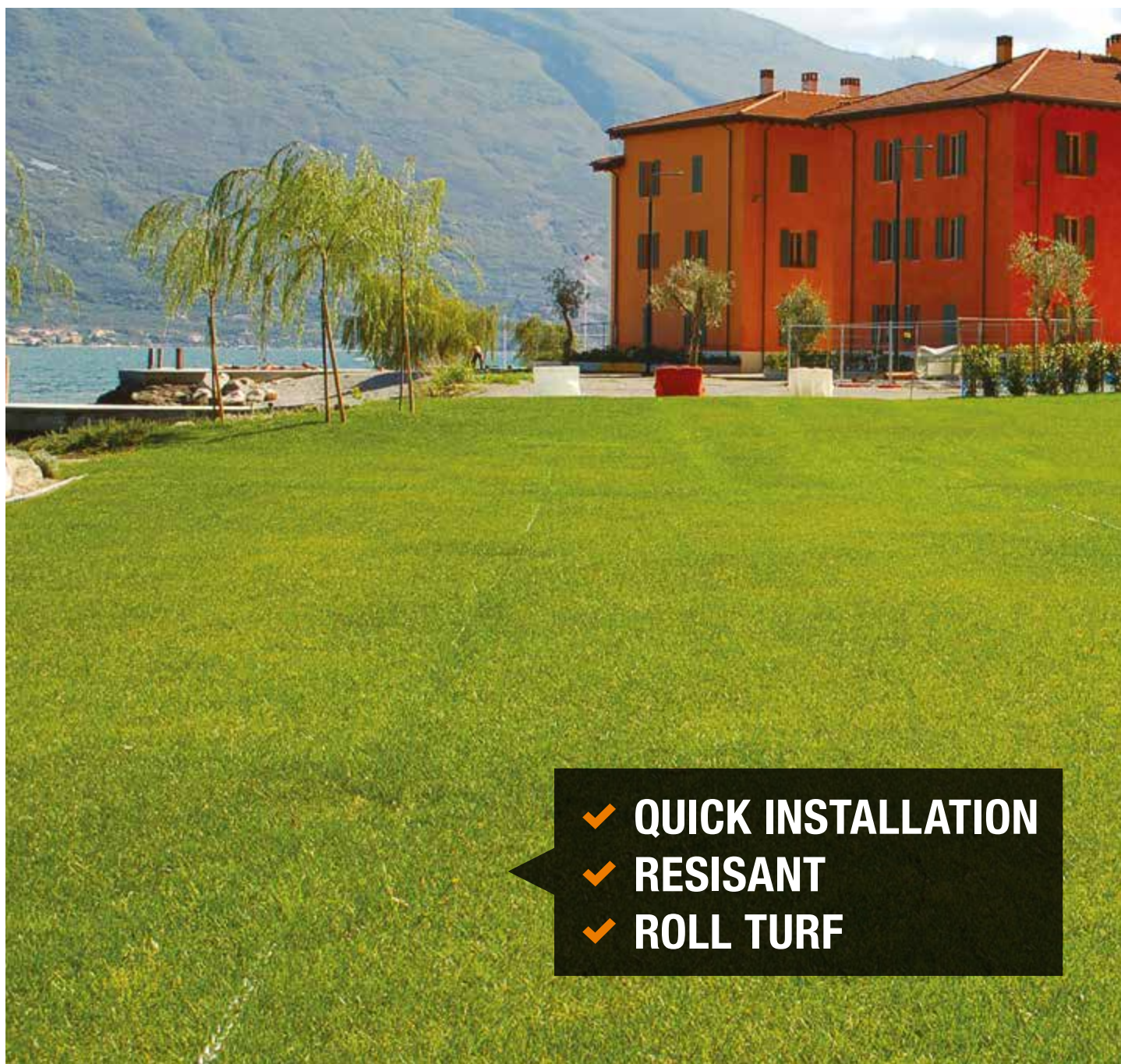

## GRASS REINFORCEMENT PAVING GRIDS





# GEOGRASS THE SOLUTION



GEOGRASS is a grid made of HD PE for the creation of car parks or grass and draining areas subjected to the transit of vehicles. The structure consists in a series of rings connected together by a net that gives a great flexibility and a high mechanical resistance to the product. Thanks to these characteristics, the grid can easily resist to the transit of heavy vehicles. Moreover, the special shape of the structure allows the consolidation of the soil and guarantees the perfect drainage of rainwater protecting the roots. A long-lasting result is certainly ensured.

## CAR PARKS AND PARKING AREAS

**MOVEMENT AREAS OR  
TRANSIT OF VEHICLES**

**LAWN  
PROTECTION**

**PEDESTRIAN PATHS**





# GEOGRASS TECHNICAL DATA



## GEOGRASS

Real size (cm)	50 x 50 x H2.5
Wall thickness (mm)	2.2
Material	HD PE
Weight (kg)	0.52
Packaging size (cm)	100 x 120 x H240
m <sup>2</sup> per pallet	200
No. pcs. per pallet	800
Load capacity (ton/m <sup>2</sup> )	400
Color	Black
Permeability	99%

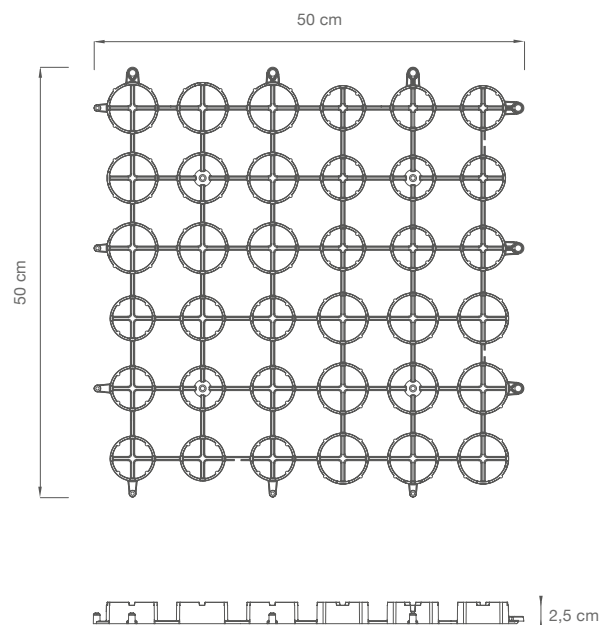

## GEOGRASS STRATIGRAPHY

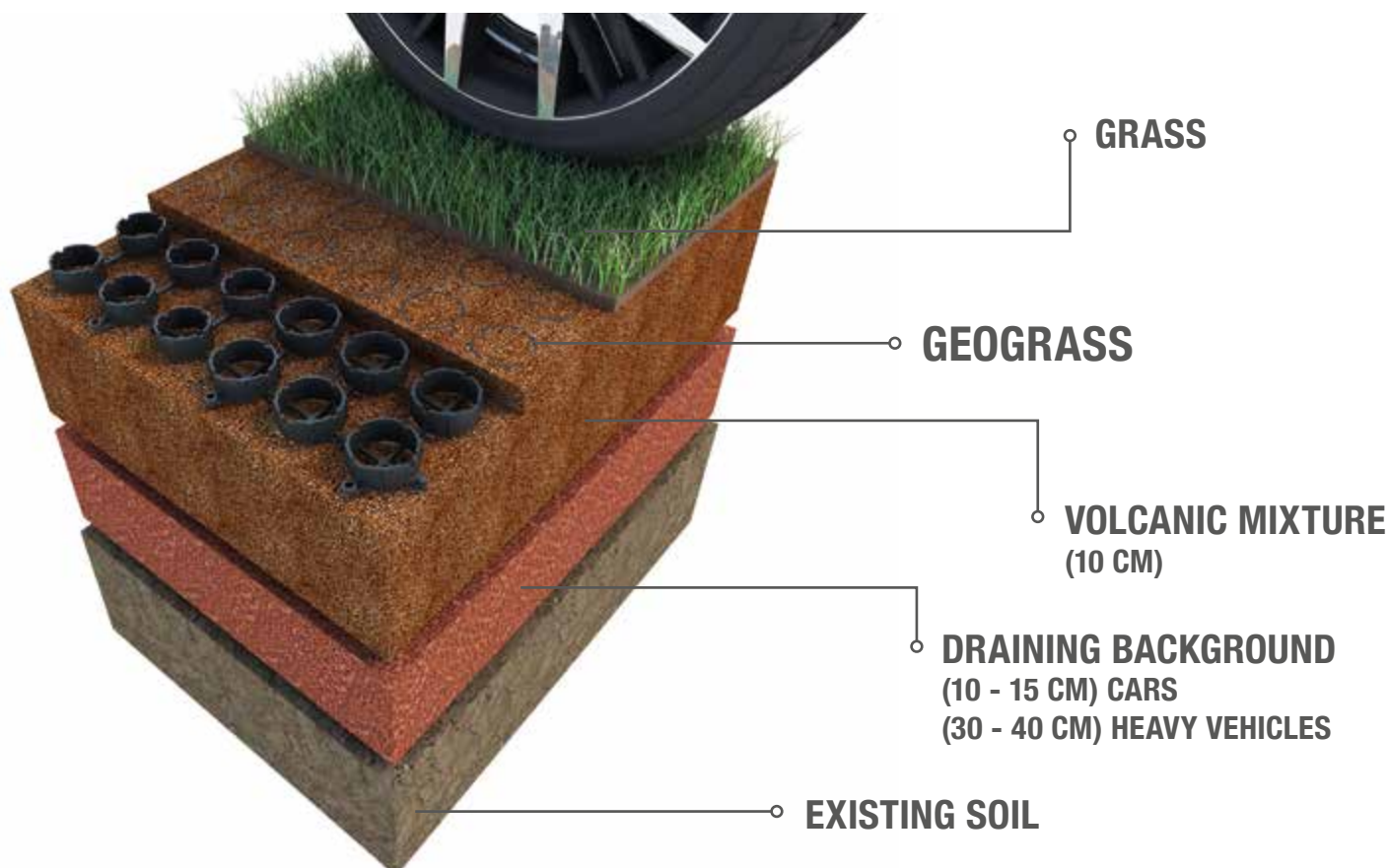

# INSTALLATION

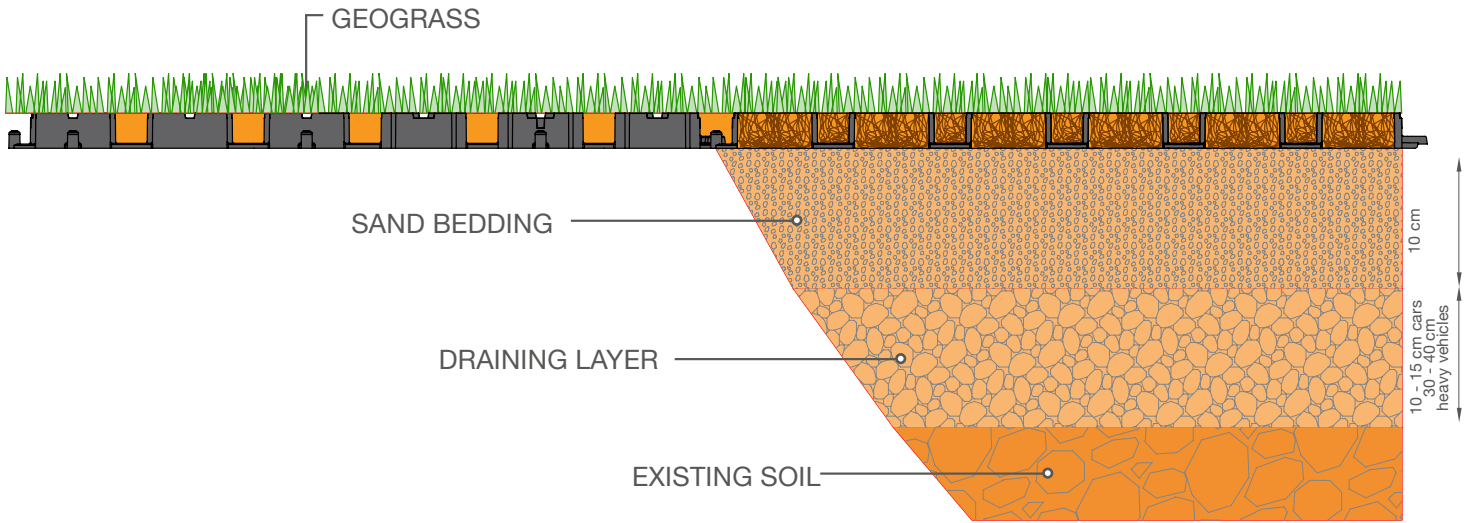

**① DRAINING BACKGROUND**  
Excavation and creation of a draining layer made of gravel or lapillus (minimum 15-20 cm).



**② LAYING BASE**  
Lay the sand bedding (at least 10 cm) of volcanic sand or silicium sand enriched with fertilizers.



**③ INSTALLATION**  
GEOGRASS installation.



**④ FILLING**  
Grid covering with the same sands of the sand bedding up to the edge.



**⑤ SEEDING**  
Grass seeding and installation of the roll of sod.



**⑥ FINAL RESULT**  
It is recommend to avoid the transit of vehicles at least until 2 or 3 grass clippings.



# GRID ADVANTAGES AND PRESCRIPTIONS



## TRANSITABLE TURF ADVANTAGES

**TOTAL PERMEABILITY**  
**INCREASE OF GREEN AREAS**  
**ENVIRONMENT MITIGATION**

## WHY GEOGRASS?

**AVOIDS THE SUB-LAYER COMPRESSION**  
**LOW MAINTENANCE OF THE GRASS**  
**TURF MAINTENANCE AND RESULT GUARANTEED**

## GEOGRASS PRESCRIPTIONS

- During the grids installation, keep the expansion joint at a distance of 3-5 cm away from the kerbs and any other obstacle.
- In case of large surfaces, it is recommended to frame an area of 30 m<sup>2</sup> providing the grids with expansion joints, without hooking them but just putting them closer instead, (leaving a span of about 1 cm).
- Design and provide it with a specific irrigation system.
- The finishing and seeding have to respect the right seasonality.
- Wait for the complete grassing before transiting over the area.
- To cut the turf, the regulation of the lawnmower blade is sufficient. It can similarly be made with snowploughs.
- GEOGRASS can be removed at a later time to ventilate the turf and carry the specific treatments.
- Restore the possible losses of filling material.

- Periodically carry out the right maintenance of the turf and possible fertilisation.
- GEOGRASS can be easily shaped with a saw or a grinding machine in close proximity of kerbs and manholes.
- The required maximal slope for transitable applications is of 8%. When it is higher, use forks or stakes to fasten GEOGRASS to the soil.



## TURF MAINTENANCE

In order to have a good turf, it is recommended to perform these common maintenance operations:

- IRRIGATION
- WEEDS AND INFESTING PLANTS REMOVAL
- MOWING
- FERTILISATION
- PLANTS OR SEEDING WHERE THE GREEN AREA MAY SUFFER A DAMAGE
- ADD MATERIAL IN CASE OF DECLINE

It is possible to obtain a perfect result over time, keeping the lawn protected even with the transit of people and vehicles on it.

# GREEN CAR PARKS

GEOGRASS is a grid with a high mechanical resistance that allows the creation of grass car parks for the parking of heavy vehicles. Its special structure avoids the ground compaction which can cause damages to the grass but also give aesthetical effect to the entire lawn. GEOGRASS conformation guarantees a perfect permeability favouring a fast disposal of rainwater and avoiding stagnations and furrows.



# LAWN PROTECTION

GEOGRASS allows the creation of stable and comfortable grass surfaces which are transitable thanks to the perfect consolidation of the soil. The grid permits the passage of the water avoiding stagnation and respecting the regulation on draining surfaces.





# SALVAVERDE



- ✓ PERMEABLE
- ✓ STABLE
- ✓ RESISTANT

**CELLULAR GRASS PAVER FOR WALKABLE AND DRIVABLE GREEN AREAS**

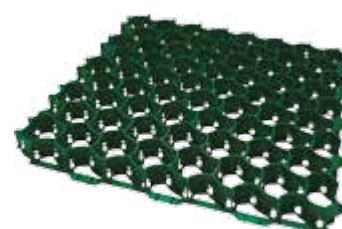



# SALVAVERDE THE SOLUTION



SALVAVERDE is the element for the creation of green parkings and green walking and driving tracks. It was specifically designed for the protection of grass surfaces. The wide structure of the cells allows a fast rooting of the grass respecting the naturalness of the soil and of the vegetation. SALVAVERDE protects the grass roots from the means of transport, while the honeycomb anti-slip surface makes the transit easy. The 95% permeability allows the right regulation of rainwater in accordance to urban planning restrictions.

**PARKING AREAS**

**PEDESTRIAN PATHS**

**BICYCLE PATHS**

**ACCESS AREAS FOR VEHICLES**

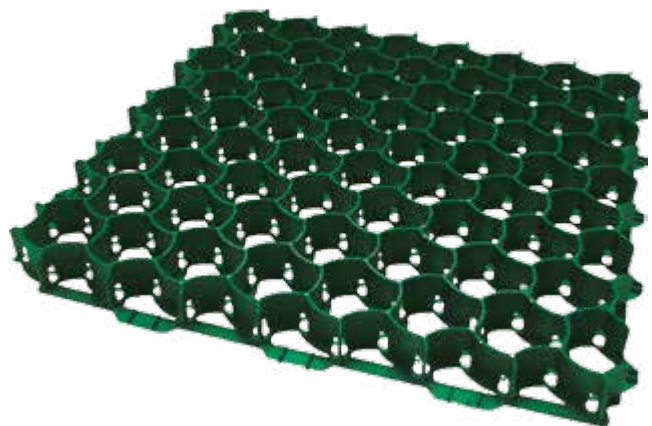



# SALVAVERDE TECHNICAL DATA

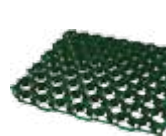
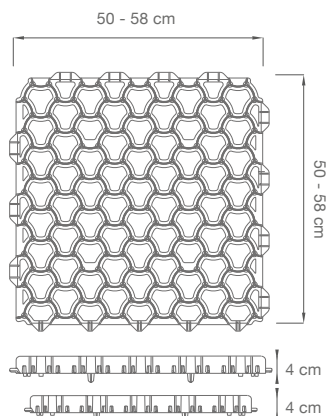

## SALVAVERDE A

## SALVAVERDE B

SIZE (cm)	50 x 50	58 x 58
HEIGHT H (cm)	4	4
Load capacity (t/m <sup>2</sup> )	350	350
Material	HD PE	HD PE
Pc. weight (kg)	0,95	1,19
Packaging size (cm)	100 x 120 x 230	120 x 120 x 240
No. pcs.	240	225
m <sup>2</sup> per pallet	60	75
Color	Green	Green
Permeability	95%	95%

## CAPS



COLOR

White ○

Yellow ●

The cap allows the marking of the parking areas, the driveways and so on. It is provided with a slip-resistant surface and an anchor rod.

## SALVAVERDE STRATIGRAPHY

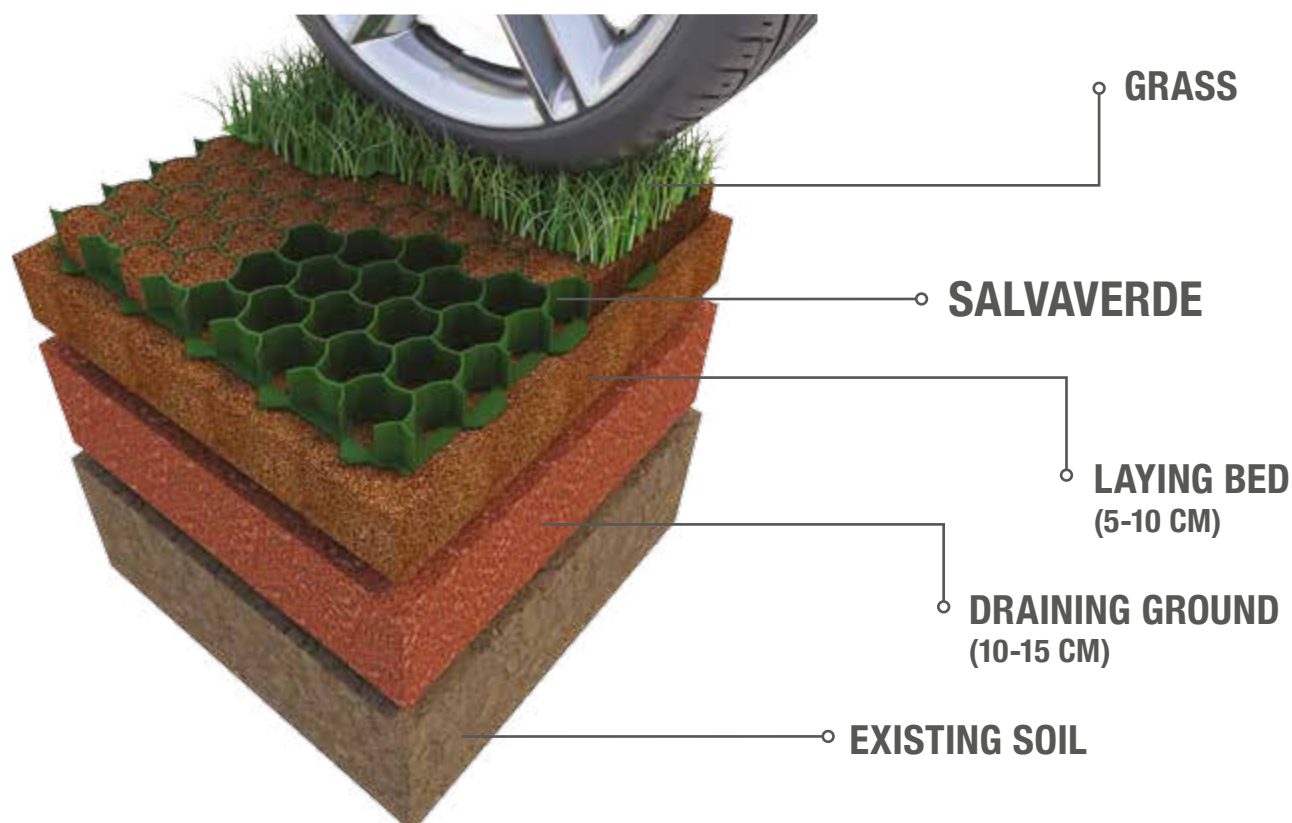

# INSTALLATION

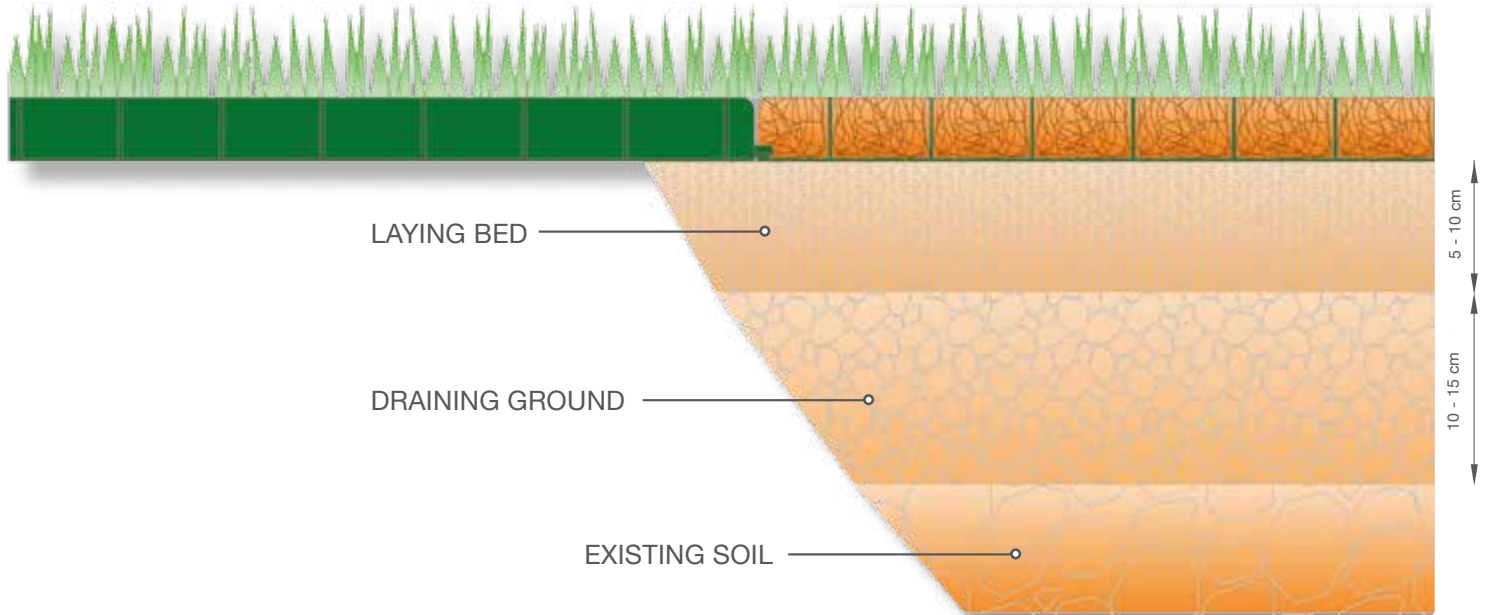

**① DRAINING GROUND 10 - 15 cm**  
Drainage layer formed by 10/15 cm of volcanic lapillus, grain size 5-20 mm, crush resistance 35 N/mm<sup>2</sup> (UNI 7549/7).



**② LAYING BED**  
Creation of SALVAVERDE Geoplast laying surface formed by 3/4 cm of volcanic sands mixture (enriched with soil and fertilizers), grain size 0-5 mm laid out and well struck in order to reach a perfect leveling.



**③ INSTALLATION**  
Installation of SALVAVERDE that guarantees the drainage of rainwater and the protection of the turf.

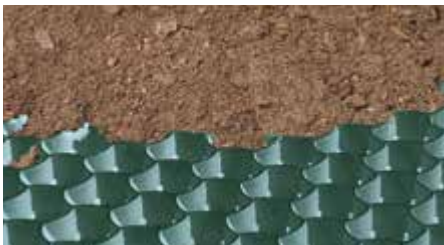

**④ SANDS FILLING**  
Cells filling with a mixture of volcanic sands enriched with topsoil and organic fertilisers (grain size 0-5 mm). Alternatively, blend of silica sand, enriched with peat and organic humos. It is recommended to avoid the transit of vehicles at least until 2 or 3 grass clippings.



**⑤ SEEDING**  
Finishing and seeding.



**⑥ DETECTING CAPS**  
Detecting caps to delimit parkings, private areas, driveways, ecc. In order to better define the parkings, 4 caps per linear meter are recommended.



# GRID ADVANTAGES AND PRESCRIPTIONS



## TRANSITABLE TURF ADVANTAGES

**TOTAL PERMEABILITY**  
**INCREASE OF GREEN AREAS**  
**ENVIRONMENT MITIGATION**

## WHY SALVAVERDE?

**AVOIDS THE SUB-LAYER COMPRESSION**  
**LOW MAINTENANCE OF THE GRASS**  
**TURF MAINTENANCE AND RESULT GUARANTEED**

## SALVAVERDE PRESCRIPTIONS

- During the grids installation, keep the expansion joint at a distance of 3-5 cm away from the kerbs and any other obstacle.
- In case of large surfaces, it is recommended to frame an area of 30 m<sup>2</sup> providing the grids with expansion joints, without hooking them but just putting them closer instead, (leaving a span of about 1 cm).
- Design and provide a specific irrigation system.
- The finishing and seeding have to respect the right seasonality.
- Wait for the complete grassing before transiting over the area.
- To cut the turf, the regulation of the lawnmower blade is sufficient. It can similarly be made with snowploughs.
- SALVAVERDE can be removed at a later time to ventilate the turf and carry the specific treatments.
- Restore the possible losses of filling material.
- Periodically carry out the right maintenance of the turf and possible fertilisation.
- SALVAVERDE can be easily shaped with a saw or a grinding machine in close proximity of kerbs and manholes.
- The required maximal slope for transitable applications is of 8%. When it is higher, use forks or stakes to fasten SALVAVERDE to the soil.



## TURF MAINTENANCE

In order to have a good turf, it is recommended to perform these common maintenance operations:

- IRRIGATION
- WEEDS AND INFESTING PLANTS REMOVAL
- MOWING
- FERTILISATION
- PLANTS OR SEEDING WHERE THE GREEN AREA MAY SUFFER A DAMAGE
- ADD MATERIAL IN CASE OF DECLINE

It is possible to obtain a perfect result over time, keeping the lawn protected even with the transit of people and vehicles on it.

# TURF PROTECTION

SALVAVERDE is the system that allows the creation of green surfaces, avoiding the problems linked to the transit of the vehicles. In this way, furrows and roots damages are avoided. SALVAVERDE consolidates and stabilises the surface, keeping the natural permeability of the soil. The draining surface that urbanization law requires, is thus fulfilled.



# TRANSITABLE TURF

SALVAVERDE is the turf protection that allows the creation of long-lasting grass parkings. The turf can always be protected from the transit of vehicles. SALVAVERDE avoids furrows and surface damages. Thanks to the large structure, SALVAVERDE guarantees an high permeability, facilitating the right disposal of rainwater. The surface is perfect for the transit of vehicles and the walkway.





# GEOGRAVEL



- ✓ **STABLE**
- ✓ **ECO-FRIENDLY**
- ✓ **PERMEABLE**

## GRAVEL STABILIZER GRID FOR DRIVEWAYS AND CAR PARKS



# GEOGRAVEL THE SOLUTION



GEOGRAVEL is the ideal solution to create gravel permeable car parks: it ensures the same performances of an asphalted area and keeps the ground permeability unchanged. The micro-perforated base of GEOGRAVEL, allows the natural draining of the water in the soil and gives stability and strength to the surface even when vehicles transit on it.

**CAR PARKS**

**FOOTPATHS**

**CYCLE PATHS**

**DRIVEWAYS**





# GEOGRAVEL TECHNICAL DATA

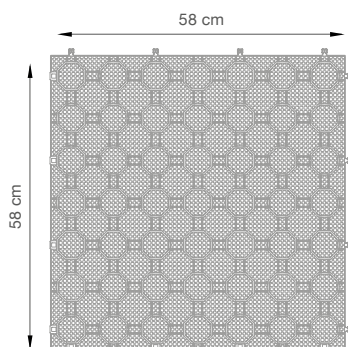

## GEOGRAVEL

Size (cm)	58 x 58 x H3
Weight (kg)	0.99
Material	HD PE
Load capability (tonne/m <sup>2</sup> )*	400
Permeability	61%
Gravel consumption (m <sup>3</sup> /m <sup>2</sup> )	0,027 m <sup>3</sup> / m <sup>2</sup>
Color	Semi-transparent white
Packaging size (cm)	120 x 120 x H240
m <sup>2</sup> per pallet	100
No. pcs per pallet	300

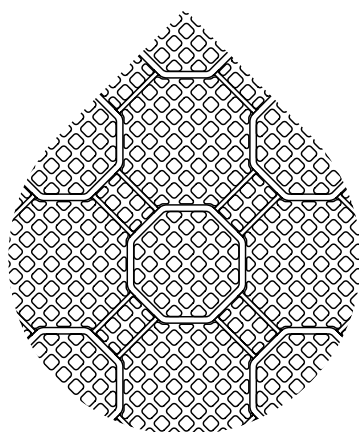

## CAPS



\* Complies with the requirements of DIN1072 - class SLW60

### COLOR

- Giallo ●
- Blu ●

The cap allows the marking of the parking areas, the driveways and so on. It is provided with a slip-resistant surface and an anchor rod.

## GEOGRAVEL STRATIGRAPHY

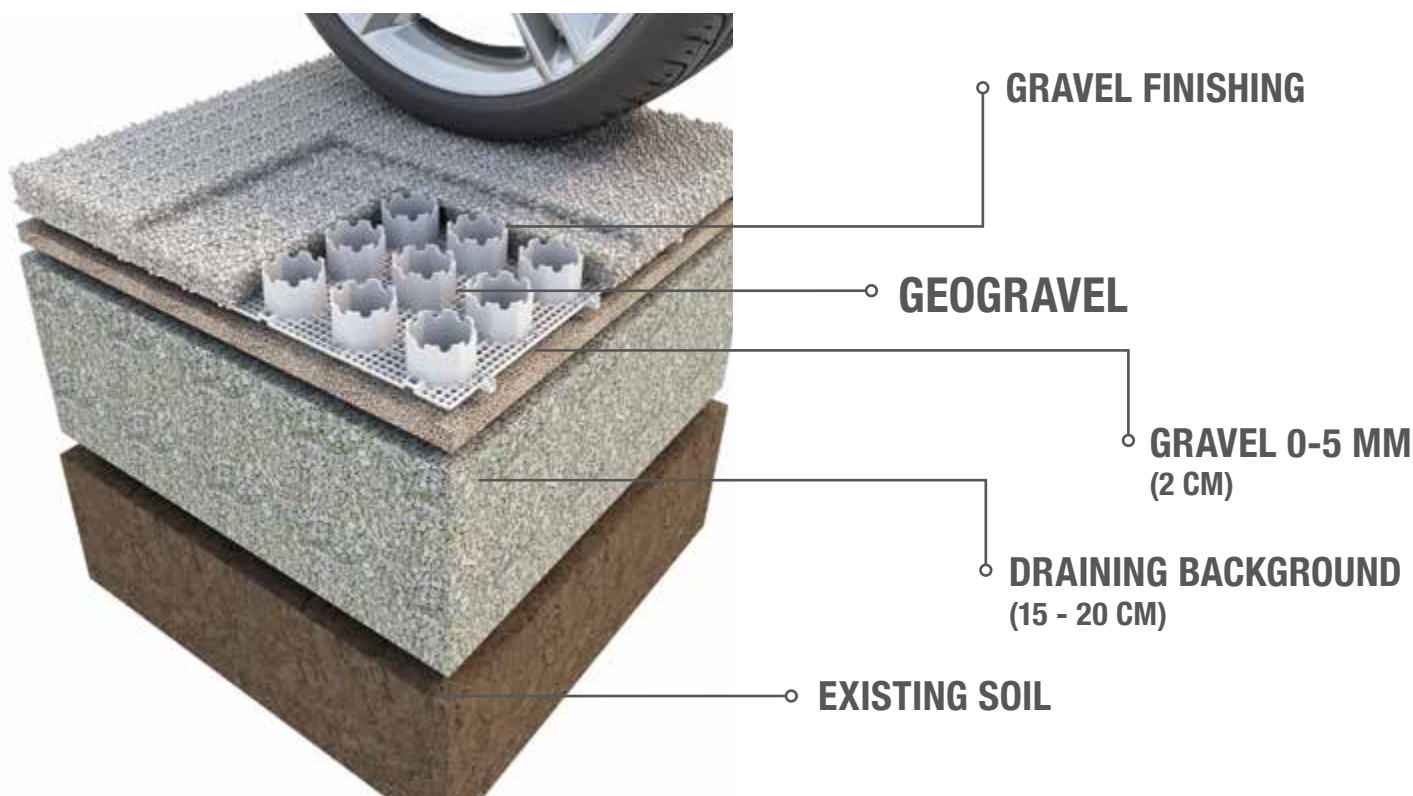

# INSTALLATION

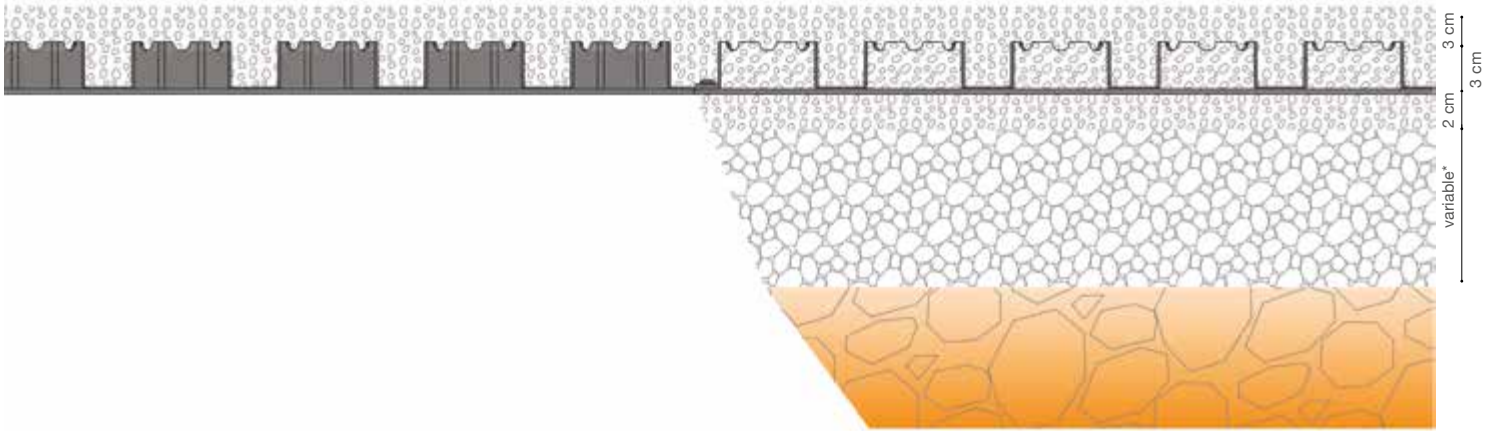

\*The thickness of the substrate can vary according to the loads.



## ① EXCAVATION AND BACKGROUND

Cleaning excavation and creation of a gravel draining bed 5-20 mm.



## ② LEVELLING

Installation of a fine pebble levelling layer 0-5 mm.



## ③ INSTALLATION

Geogravel installation.



## ④ FILLING

Fill the grid with fine pebble from 5-10 mm up to 3 cm on the cells.



## ⑤ LAYING

Gravel manual compaction.



## ⑥ FINAL RESULT

After the correct installation, Geogravel can be used.



# INSTALLATION PRESCRIPTIONS

## WALKWAYS, BICYCLE PATHS, DISABLED ACCESSES

① Permeable sub-base of 8/10 cm with compacted crushed gravel (crushed limestone, porphyry or crushed concrete), granulometry 5-20 mm\*.

② Gravel levelling layer 2 cm thick, granulometry 0-5 mm.

③ GEOGRAVEL installation.

④ Fill the grids with decorative gravel, up to 3 cm over the height of the cells

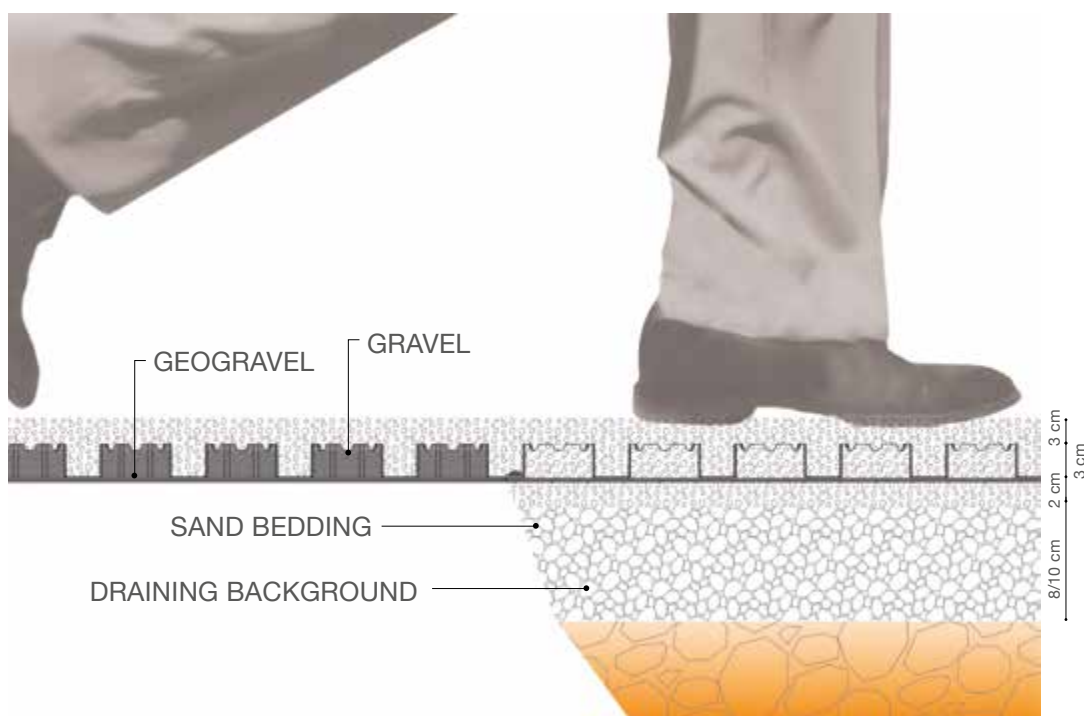

## VEHICLES

① Permeable sub-base of 18/20cm with compacted crushed gravel (crushed limestone, porphyry or crushed concrete), granulometry 5-20 mm\*.

② Sand bedding 2 cm thick of gravel granulometry 0-5 mm.

③ GEOGRAVEL installation

④ Filling of the grids with decorative gravel 3 cm over the height of the cells.

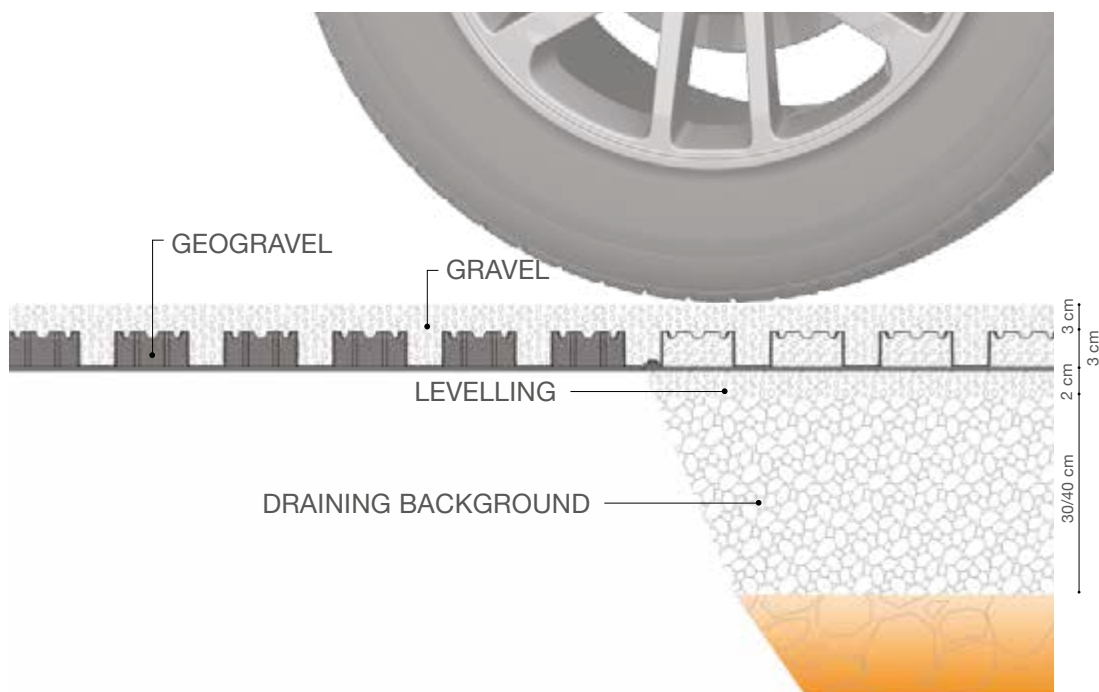

## HEAVY VEHICLES

① Permeable sub-base of 30/40 cm with compacted crushed gravel (crushed limestone, porphyry or crushed concrete), granulometry 5-20 mm\*

② Sand bedding 2 cm thick of fine gravel, granulometry 0-5 mm.

③ GEOGRAVEL installation.

④ Filling of the grids with decorative gravel 3 cm over the height of the cells.



\* The thickness of the substrate can vary according to the load-bearing capacity of the natural subsoil.

# ADVANTAGES AND ADVICES TO GET A BETTER RESULT

- The sand bedding needs to be compacted and levelled in order to avoid the lifting of the elements.
- During the grids installation, an expansion joint should be placed at 3-5 cm from the kerbs.
- In case of large surfaces it would be appropriate to frame areas of about 30 sqm and provide them with expansion joints in order to place the grids without hooking them (you should keep them at a distance of about 1 cm from one another).
- GEOGRAVEL can be easily shaped in proximity to kerbs or wells.
- If the filling material finishes, you need to add more of it because the grids have to be completely covered.
- Fill the cells with gravel, 3 cm over the edge. The grids needs to be completely covered.



**WITHOUT GRID**

## ADVANTAGES OF A GRAVEL AREA

- Total permeability
- Easy maintenance
- Cost-saving material



**WITH GRID**

## WHY THE GRID?

- Elimination of soil subsidence
- Elimination of the dust lift-off
- The micro-perforated grid makes the ground stable

## SAFE AND COMFORTABLE

GEOGRAVEL PROVIDES STABILITY TO THE GRAVEL BED, avoiding the side movement of the grid and the material loss. Thanks to the high quality of the material, Geog gravel allows also the safe and comfortable transit of vehicles and people (no gravel or dust lift-off).



# FOOTPATHS

GEOGRAVEL is the ideal solution to create gravel surfaces like yards, footpaths or driveways. GEOGRAVEL provides stability to the surface making the passage safe and comfortable also for wheelchairs, strollers and bikes. Its high permeability permits a fast drainage of the water in the subsoil avoiding the formation of puddles or stagnations.



# CAR PARKS

GEOGRAVEL is the ideal solution to create permeable car parks that guarantee a high comfort and keep the draining capacity of the soil unaltered. GEOGRAVEL cells hold back the gravel and avoid any maintenance typical in green car parks.



# GEOROAD



**PLASTIC GROUND PAVER FOR REINFORCEMENT  
OF ROAD VERGES**





# GEOROAD THE SOLUTION



GEOROAD is a HD PE panel, designed to consolidate the road's verges subjected to problems of subsidence; its rhombus structure allows, in fact, to reduce significantly the forces of lateral thrust caused by the passage of vehicles. The reduced width permits the easy adaptation to any marginal zone of the roadway. Thanks to the double elastic connecting coupling between the panels GEOROAD, the effects of thermal expansion are removed and the installation is quickly, both in the straight and curved sections.

**SIDE ROADS**

**ROADS FOR TRANSIT OF FARM MACHINERY**

**ROUNDBABOUTS**

**STREETS CENTRAL LANES**

**PRIVATE DRIVEWAYS**

**CURVES**



# GEOROAD TECHNICAL DATA



## GEOROAD

Real size (cm)	77 x 40.5 x H2.8
Material	HD PE
Weight (kg)	1.16
Packaging size (cm)	83 x 120 x H240
m <sup>2</sup> per pallet	74.85
No. pcs. per pallet	240
Load capacity (ton/m <sup>2</sup> )	500
Color	Black

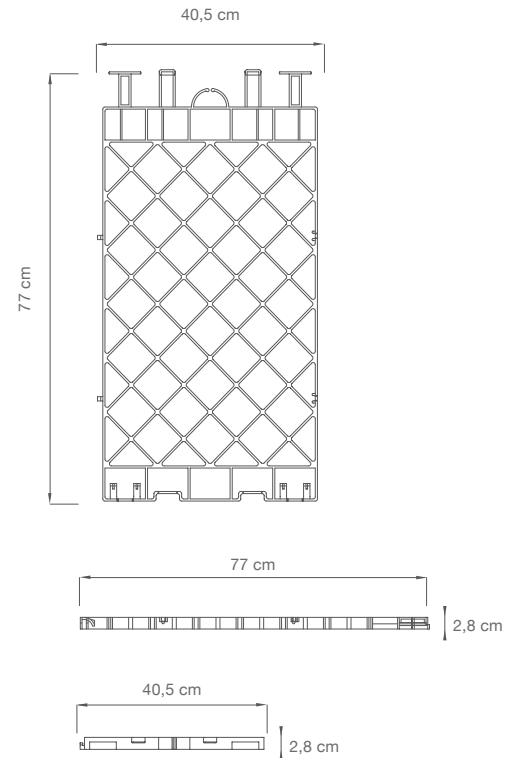

## FRONTAL COUPLING DETAILS

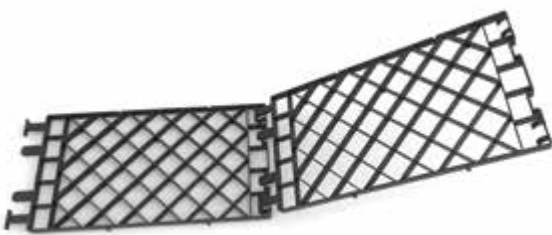

GEOROAD 's joint is designed to allow a connection between the panels resistant to the stresses related to the applied loads, and to permit a rotation of 5° between one element and another for the installation along curves.

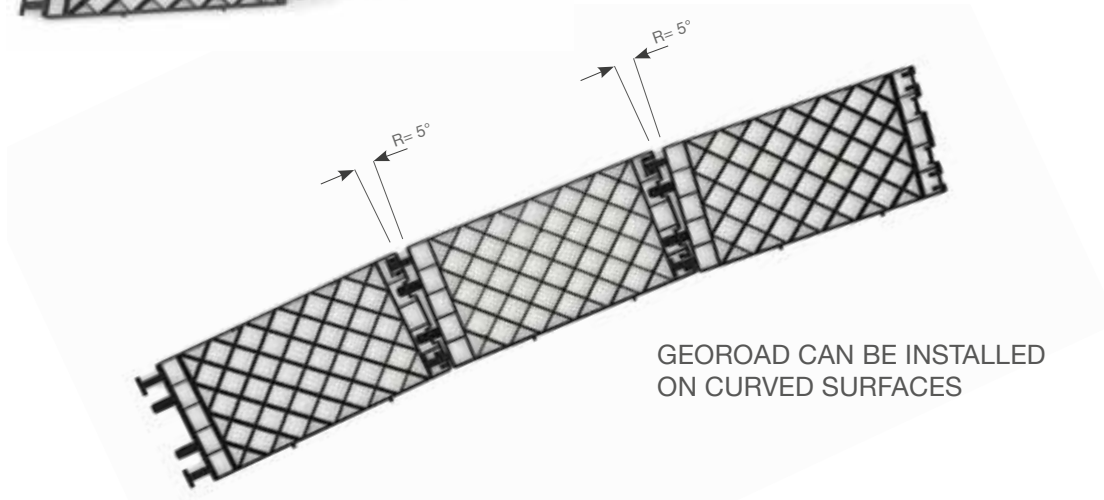

GEOROAD CAN BE INSTALLED ON CURVED SURFACES



# INSTALLATION



## ① LAYING

Apply a supporting layer which can withstand to the stress of the transiting vehicles.



## ② INSTALLATION

Install GEOROAD on the road quay.



## ③ LEVELLING

Cover up to the edge of GEOROAD with finegrained. It is possible to cover the surface with grass too.



## ④ FINAL RESULT

After the correct installation, GEOROAD can be used.

# GEOROAD INSTALLATION

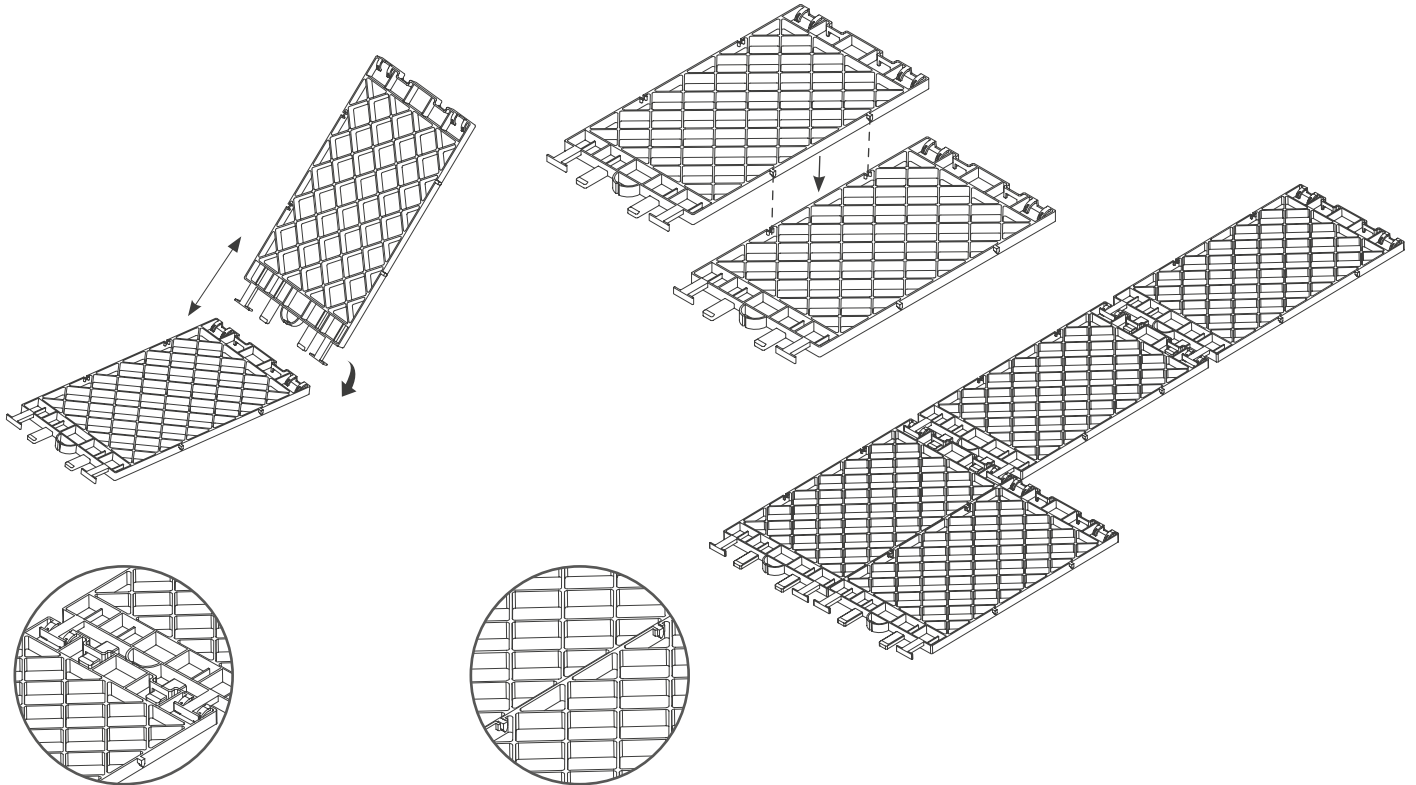

**FRONTAL  
CONNECTION**

**SIDE  
CONNECTION**

## INSTALLATION ALONG CURVED SURFACES

Thanks to the double flexible joint integrated in the panel, GEOROAD can be installed on curved surfaces and roundabouts.

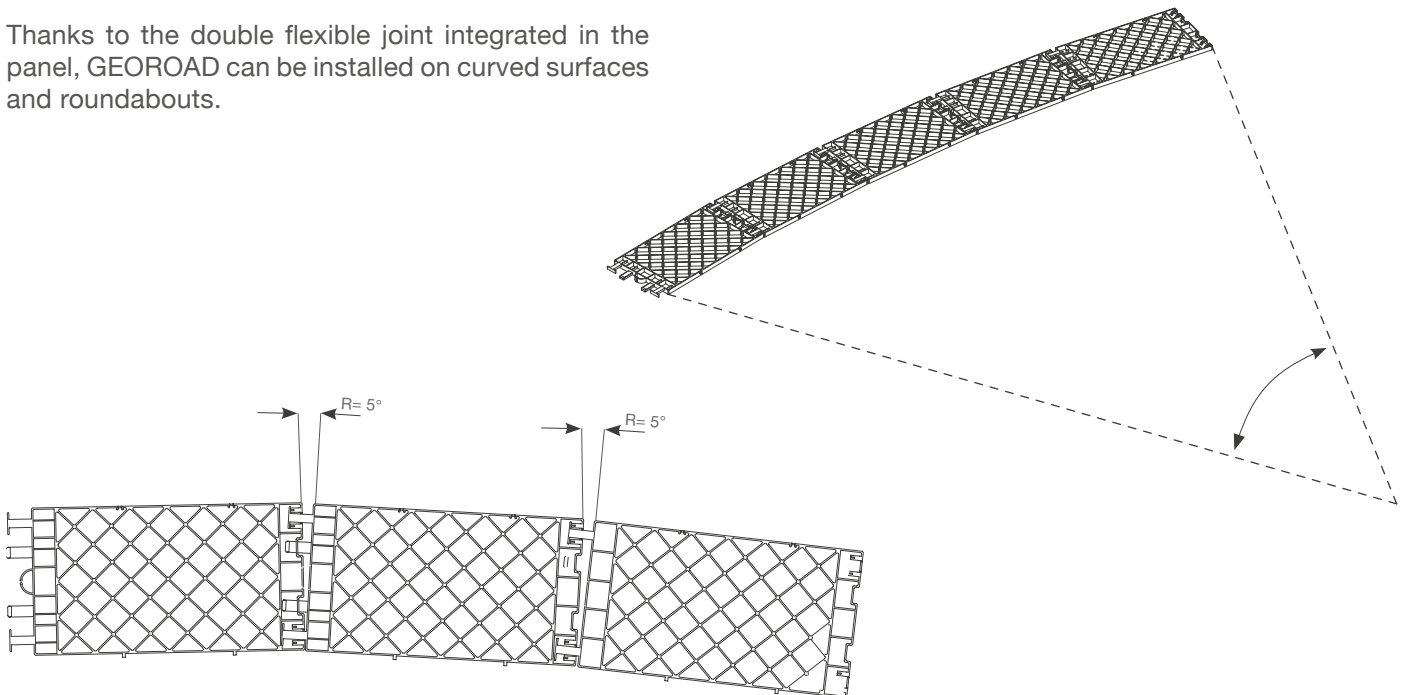



# STABILIZATION OF ROAD VERGES



## MORE SAFETY FOR THE TRANSIT OF VEHICLES

With its robust and resistant to mechanical stress structure, GEOROAD allows the consolidation of the carriageway subjected to subsidence, both in straight and in curved sections, thanks to the special joint that allows a partial rotation of the elements. GEOROAD has a completely permeable surface, which permits the passage of rain water, eliminating any problem of stagnation.





# DRAINROOF



## HIGH-PERFORMANCE GREEN ROOF DRAINAGE BOARD





# DRAINROOF THE SOLUTION



DRAINROOF is the drainage and accumulation element for the creation of roof gardens on slabs and plates made of concrete. It was specifically designed for green roofs because it offers a high rainwater disposal capability, avoiding stagnation and protecting the waterproofing layer. DRAINROOF high load capacity allows the creation of any type of garden, extensive light gardens and more usable intensive gardens. The panel of two different heights, 6 and 2.5 cm, allows the ventilated crawl space to grow and they also help to limit the coverage thickness.

**ROOF GARDENS**

**GREEN TERRACES**

**SET OF GREEN ISOLATING PACKAGES**

**COVERING OF UNDERGROUND GARAGES**



# DRAINROOF TECHNICAL DATA

## DRAINROOF H2,5

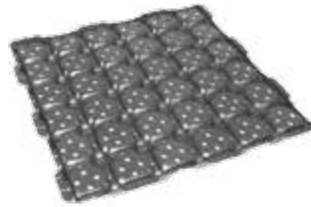
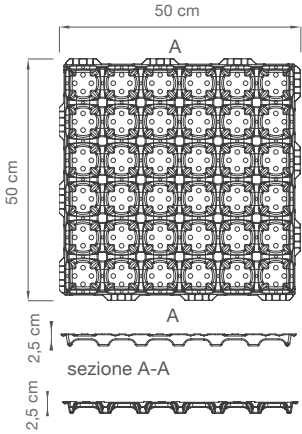

## DRAINROOF H2,5

REAL SIZE (cm)	50 x 50 x 2.5
Material	PP
Compression resistance (kg /m <sup>2</sup> )	3.200
Weight m <sup>2</sup> (kg)	2.56
Weight per item (kg)	0.64
Draining surface (cm <sup>2</sup> /m <sup>2</sup> )	547
Water storage (l/m <sup>2</sup> )	1.32
Discharge Volume	17.2
Solubility	Resistant to organic, acid, alkaline and alcoholic substances
Packaging dimension (cm)	105 x 120 x 230
Items per pallet	1.440
m <sup>2</sup> per pallet	360

## DRAINROOF H6

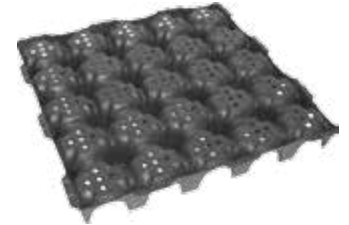
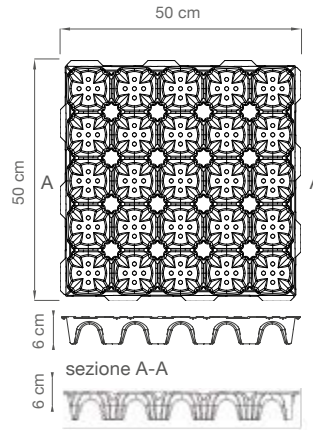

## DRAINROOF H6

REAL SIZE (cm)	50 x 50 x 6
Material	Regenerated polypropylene
Compression resistance (kg /m <sup>2</sup> )	6000
Weight m <sup>2</sup> (kg)	4.28
Weight per item (kg)	1.07
Draining surface (cm <sup>2</sup> /m <sup>2</sup> )	318
Water storage (l/m <sup>2</sup> )	12
Discharge Volume	40
Solubility	Resistant to organic, acid, alkaline and alcoholic substances
Packaging dimension (cm)	105x 120 x 240
Items per pallet	720
m <sup>2</sup> per pallet	180

## GEO-TEXTILES ACCESSORIES

### GEO-TEXTILE 200 g/m<sup>2</sup>

Textile protection of the layer during the installation

Weight (g/m <sup>2</sup> )	200
Thickness (mm)	1.20
Tensile strength (kg/m) long.	1.8 trasv. 2.3
Extension with fractures (%) long.	80 trasv. 80

### GEO-TEXTILE 150 g/m<sup>2</sup>

Textile separation from the underlayer

Weight (g/m <sup>2</sup> )	150
Thickness (mm)	0.90
Tensile strength (kg/m) long.	11 trasv. 11
Extension with fractures (%) long.	55 trasv. 55



# THE BENEFITS OF ROOF GARDENS



## SHEATH PROTECTION

From the sudden temperature changes, from the UV rays and from the atmospheric agents. The coverage life grows of the 20%.

## LOWERING OF THE RUN-OFF PEAKS

A roof garden absorbs the 50% of rainwater, lowering the quantity to dispose it in the urban sewer.

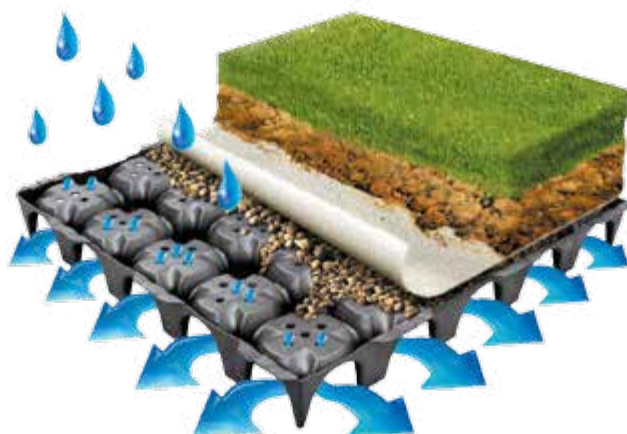

## MICROCLIMATE REGULATION

Through the evaporation and evapotranspiration of the absorbed water, in order to refresh the environment.

## INCREASE OF THE COMMERCIAL VALUE

The roof garden offers new usable spaces and increases the energy profit of building's coating.

## INCREASE OF THE PHOTOVOLTAIC PROFIT

Thanks to the maintenance of a more stable temperature, within the range to obtain an high profit.

## THERMAL AND ACOUSTIC INSULATION

The green set is used as an insulating layer: in winter it isolates thermally, while in summer it is used as a solar shield.

# DRAINROOF EXTENSIVE ROOF GARDEN



The typical application of the extensive roof garden is the green roof, which is created with plants that do not require maintenance and irrigation, as the sedum and other similar species. These plants need a limited thickness underlayer: the set is light and can be installed on any existing roof, both plane and inclined. The extensive set is easy to realize and maintain. It absorbs most of the rainfalls, protects the coverage and isolates the building thermally. Keeping a stable temperature, it can improve the yield of the photovoltaic panels which are generally pulled alongside.

The extensive roof garden can be used with DRAINROOF 6 o DRAINROOF 2,5 cm depending on the project.

## CHARACTERISTICS

Cost-effective set

Lower costs of maintenance and realization

Different biodiversity levels depending on the species

Weight	70 - 250 Kg/m <sup>2</sup>		
Vegetation type	Sedum	Perennial grass	Turfs
Sub-layer thickness	8 cm	15 cm	20 cm
Water retention	50 - 60%		
Water accumulation volume	min 20 l/m <sup>2</sup>		
Ecological value	Good		
Installation savings	Excellent		
Maintenance savings	Excellent		



# EXTENSIVE ROOF GARDEN STRATIGRAPHY

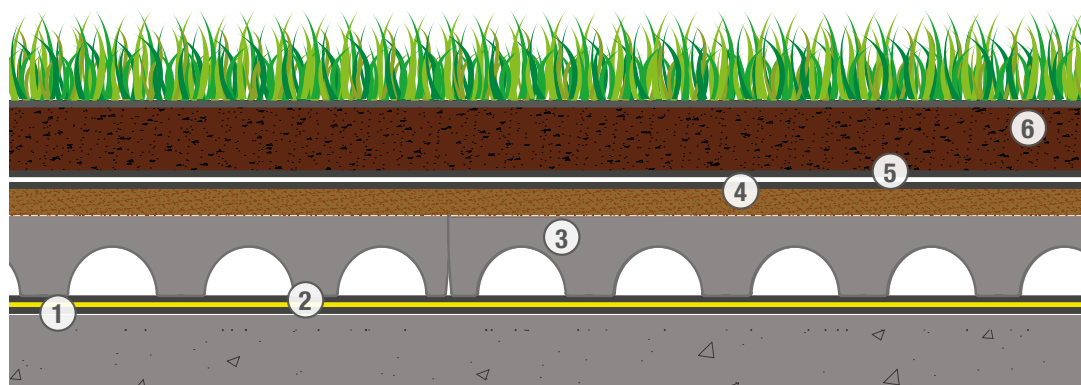

THE VEGETATION can be created with seeding, hydro-seeding or can be sod laid.

- ① WATERPROOFING LAYER      ② GEO-TEXTILE 200 g/m<sup>2</sup>      ③ DRAINROOF H6 O H 2,5  
 ④ VOLCANIC LAPILLUS      ⑤ GEO-TEXTILE 150g/m<sup>2</sup>      ⑥ SUB-LAYER



## ① WATERPROOFING LAYER

The system should be provided with a waterproofing element which resists to the roots and to the microorganisms. These functions can be avoided using various layers (waterproofing sheath-antirroot membrane) or a single system.



## ② GEO-TEXTILE 200g/m<sup>2</sup>

In order to protect the waterproofing elements more, the installation of a Geo-textile TNT 200 g/m<sup>2</sup> is recommended. Roof gardens require also a concrete slab floor as a protection.



## ③ DRAINROOF H 6 O H 2,5

DRAINROOF panels can be used both for extensive and intensive roof gardens. The choice of the panel depends on the storage volume of the water, required by the need of limiting the thickness of the finished set.



## ④ VOLCANIC LAPILLUS

Filling of DRAINROOF H6 up to a thickness of 2 cm over the edge of the element with pumice stone or volcanic lapillus, grain size 10-12 mm, high water absorption capacity (not required for DRAINROOF H2,5).



## ⑤ GEO-TEXTILE 150 g/m<sup>2</sup>

Place the TNT of 150 g/m<sup>2</sup> geo-textile between the filling material and the sub-layer. The geo-textile works as a filter for the water of dissolved particles.



## ⑥ SUB-LAYER

The thickness varies from the types of plants that are going to be planted on the surface. Thickness 8 and 20 cm.

# DRAINROOF INTENSIVE ROOF GARDEN



The intensive roof garden can be used as a real garden. Therefore, it requires a stratigraphy capable of housing high-stem trees because the set thickness is large and the slab can easily sustain a heavy load. It is certainly a more expensive solution in terms of maintenance and realization, but at the same time it guarantees many performance benefits. An intensive roof garden is able to absorb a high quantity of rainwater in order to better manage the water in the housing and urban areas. It can be used as an isolating layer, lowering the peaks of heat during summer and as a thermal insulation coating in winter.

The intensive roof garden can be realized with DRAINROOF 6 or DRAINROOF 2,5 cm depending on the project.

## CHARACTERISTICS

Completely usable space

High energy efficient set

High level of biodiversity

An automatic irrigation system is required

Weight	> 300 - 2000 kg/m <sup>2</sup>		
Vegetation type	Turfs	Shrubs	Trees
Sub-layer thickness	30 cm	50 cm	80 cm
Water retention	70 - 95%		
Water accumulation volume	min 45 l/m <sup>2</sup>		
Ecological value	Excellent		
Installation savings	Excellent		
Maintenance savings	Good		



# INTENSIVE ROOF GARDEN STRATIGRAPHY

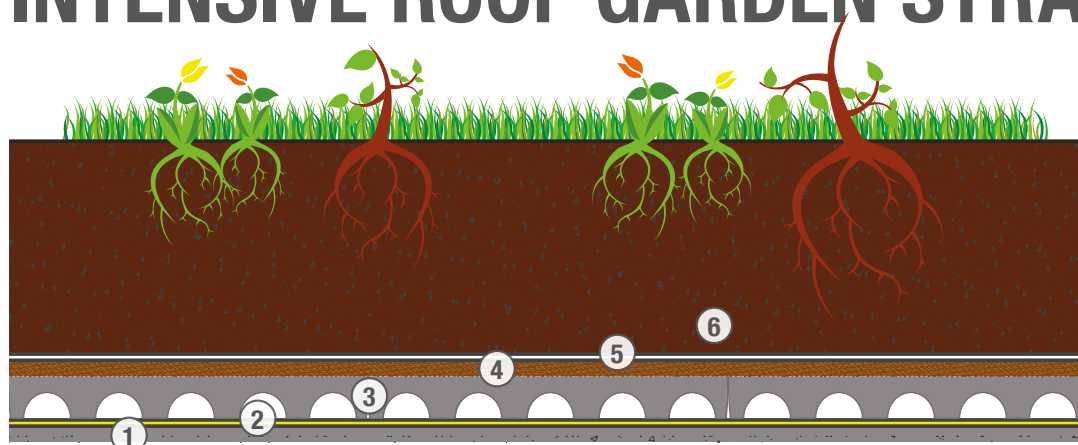

THE VEGETATION can be realized with seeding, hydro-seeding or can be sod laid.

- |                       |                                    |                        |
|-----------------------|------------------------------------|------------------------|
| ① WATERPROOFING LAYER | ② GEO-TEXTILE 200 g/m <sup>2</sup> | ③ DRAINROOF H6 O H 2,5 |
| ④ VOLCANIC LAPILLUS   | ⑤ GEO-TEXTILE 150g/m <sup>2</sup>  | ⑥ SUB-LAYER            |



## ① WATERPROOFING LAYER

The system should be provided with a waterproofing element which resists to the roots and to the microorganisms. These functions can be avoided using various layers (waterproofing sheath-antirroot membrane) or a single system.



## ② GEO-TEXTILE 200 g/m<sup>2</sup>

In order to protect the waterproofing elements more, the installation of a Geo-textile TNT 200 g/m<sup>2</sup> is recommended. Roof gardens require also a concrete slab floor as a protection.



## ③ DRAINROOF H 6 O H 2,5

DRAINROOF panels can be used both for extensive and intensive roof gardens. The choice of the panel depends on the storage volume of the water, required from the need of limiting the thickness of the finished set.



## ④ VOLCANIC LAPILLUS

Filling of DRAINROOF H6 up to a thickness of 2 cm over the edge of the element with pumice stone or volcanic lapillus, grain size 10-12 mm, high water absorption capacity (not required for DRAINROOF H2,5).



## ⑤ GEO-TEXTILE 150 g/m<sup>2</sup>

Place the TNT of 150 g/m<sup>2</sup> geo-textile between the filling material and the sub-layer. The geo-textile works as a filter for the water of dissolved particles.



## ⑥ SUB-LAYER

The thickness varies from the types of plants that are going to be planted on the surface. Thickness 8 and 20 cm.

# SEDUM EXTENSIVE ROOF GARDEN

DRAINROOF is the more efficient system for rainwater disposal. Its dome structure allows the creation of channels which can dispose the water even during heavy rainfalls. The water stagnation is eliminated thanks to the ventilated cavity. DRAINROOF is also designed to make the place safe and easy and can be easily moulded according to the needs.



# SLOPING ROOF EXTENSIVE GARDEN

DRAINROOF allows the creation of a real protection layer on the roof. The underlayer absorbs almost the 50% of rainwater, favouring the water management and giving back to the surface the initial portion of lawn. In this way, the biodiversity is safeguarded and the energy efficiency standard is reached.





# INTENSIVE ROOF GARDEN

DRAINROOF is characterized by high resistance and high load capability and allows the creation of any stratigraphy, housing high-stem trees too. Thanks to its resistance it is possible to use mechanical means without damaging the while waterproof sheath. Moreover, thanks to the ventilated separation that DRAINROOF creates, the water stagnation and the roots descendance until the covering layer is avoided.



# SLOPING ROOF INTENSIVE GARDEN

DRAINROOF was specifically designed for coverings, and it is very easy to place. The coupling system links the panels with each other, avoiding liftings and movements; moreover the dome structure made of plastic avoids any flotation phenomenon. DRAINROOF cannot get soaked in water and resists to chemical agents.



# DRAINROOF COMPLETA

## TRAY FOR PRE-GROWN GREEN ROOF MODULES



COMPLETA is the last generation of pre-grown sedum extensive green roofs. It can be easily installed both on flat or sloping roofs and is also extremely light (60 kg/sqm. in conditions of water saturation). The product does not require a particular maintenance and can be easily removed for any roof inspection after the installation.

### SYSTEM'S COMPOSITION

**DRAINROOF COMPLETA**

- Storage and drainage element clogged with grains of pumice fl 4/8 mm.
- Separation Geo-textile (300 gr/sqm).
- Cultivation sub-layer with Sedum spp. and Mesembrianthemum cooperi
- Broken or round gravel fl 16/32 all over the surface

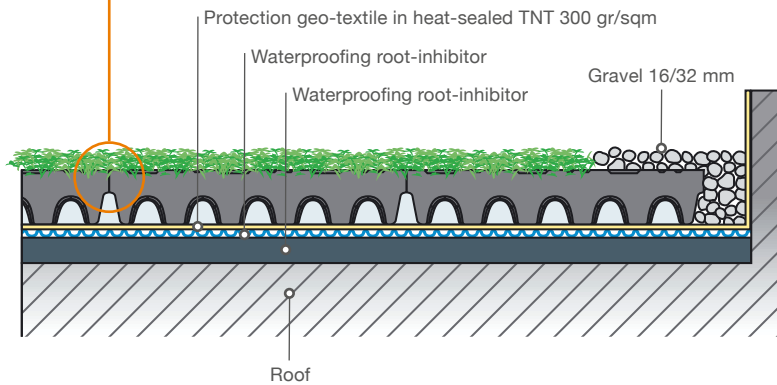

Total weight of the water saturated system 50-60 kg/sqm

### DRAINING MODULE TECHNICAL DATA

Material	PP
Size	cm 54 x 54 x 9 h
Compressive strength	2000 kg/m <sup>2</sup>
Draining surface	1144 cm <sup>2</sup> /m <sup>2</sup>
Water reserve	20 lt/m <sup>2</sup>
Weight	4.84 Kg/m <sup>2</sup>
Plastic support color	Black



## CLOD LAYING

The modules are laid and connected between each other through the double overlapping coupling system. Once the installation on-site is completed, water abundantly all the surface until the soil saturation is reached.

## PERIODICAL CARE

The system does not require grass mowing or pesticides treatments, but on the other hand, emergency irrigations in case of long periods of drought during summer are recommended. This will help to keep a flourishing appearance to the roof. Besides a 6-monthly/annual fertilisation, no other intervention is needed.





# WALL-Y



## MODULAR ELEMENT FOR GREEN WALLS

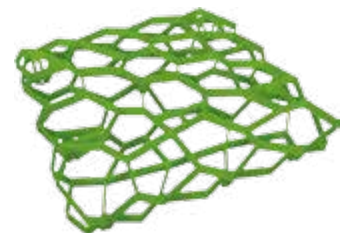



# WALL-Y THE SOLUTION



WALL-Y is the perfect solution to create vertical green walls and to delimit spaces and green areas such as gardens. WALL-Y resists to weathering, improves energy performances of the building and makes it more beautiful and comfortable. The original texture of the grid, available in many colours, adorns walls even before they are covered with vegetation. WALL-Y is ideal for existing and new buildings and it has also a great aesthetic and environmental value in an urban context.

## GREEN WALLS

## DELIMITATION OF GREEN AREAS AND GARDENS

## MODULAR GREEN WALLS

## DELIMITATION OF TERRACES

## OPEN SPACES

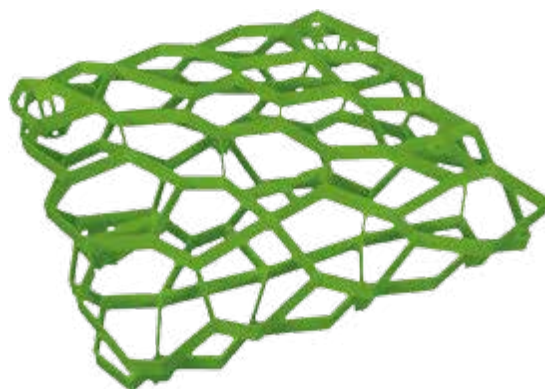

# WALL-Y TECHNICAL DATA

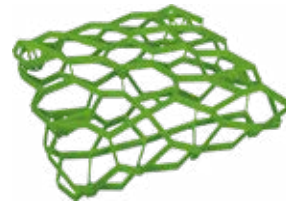
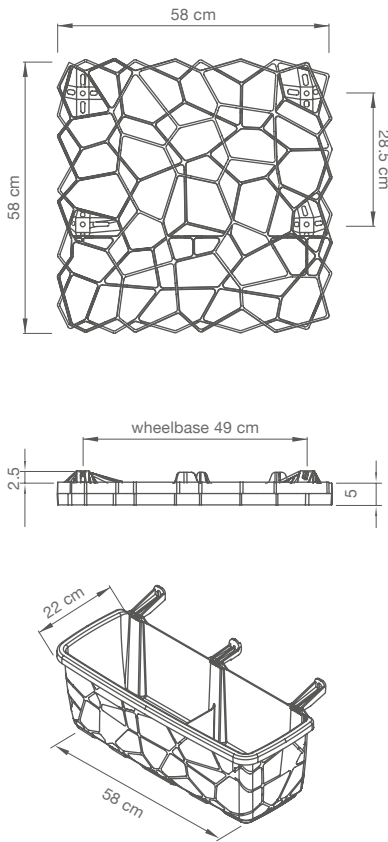

**GRID**



**POT**

Real size (cm)	58 x 58 x 7.5	58 x 22 x 20
Material	HD PE	HD PE
Weight (kg)	1.45	1.32
Packaging size (cm)	120 x 120 x 240	100 x 120 x 200
No. pcs. per pallet	180	100
m <sup>2</sup> per pallet	60	-

Color\* Green - White Green - White

\* Custom colors are possible

## MATERIAL CHARACTERISTICS

Bending elasticity module	780 N/mm <sup>2</sup>
Tensile strength breaking load	22 N/mm <sup>2</sup>
Thermal expansion coefficient	0.2 mm/m/°C

## WALL-Y CHARACTERISTICS

Type of interlocking system between grids	Double overlap
Horizontal distance fixing holes (cm)	49
Vertical distance fixing holes (cm)	28.5
Diameter fixing holes (mm)	10
Grid thickness (cm)	5
Fastening feet height (cm)	2.5

## THE POT



Suitable for a fast greening of the wall or to cover large surfaces, this accessory hosts the plants and makes possible multiple aesthetic effects.

It is possible to install one pot per grid.

In order to get more info about the maximal applicable load vertically on the pot, consult the available technical material on the website or contact our experts (see page 3).



# INSTALLATION INSTRUCTIONS

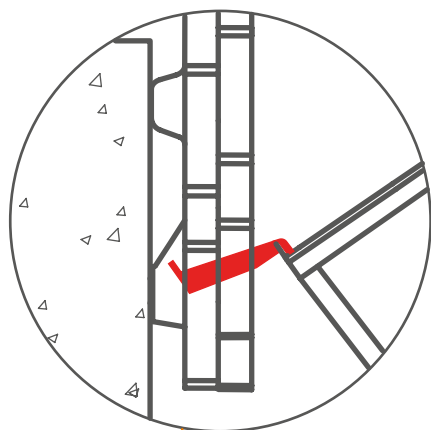

## THE COUPLING SYSTEM

It is necessary to pay attention to the correct insertion of the three supports of the pot (two lateral supports with the slot for the insertion of the wall connection and the central support). These must be inserted in the three spaces of WALL-Y, in order to guarantee the best stability to the grid.

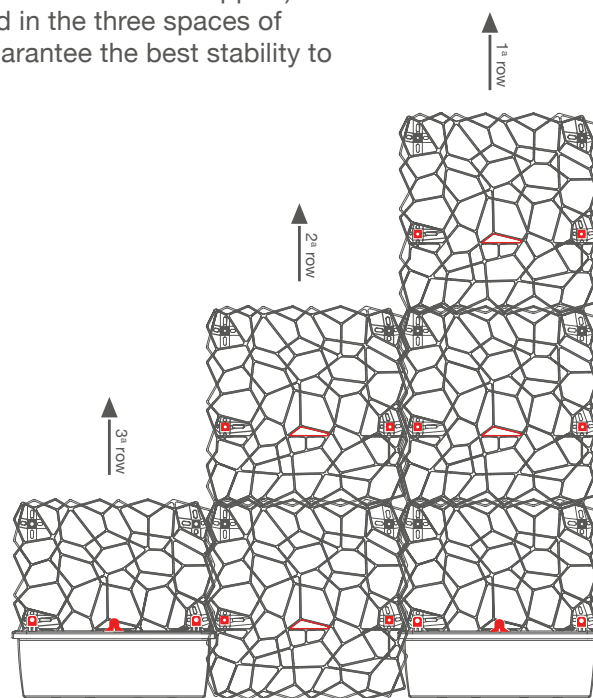
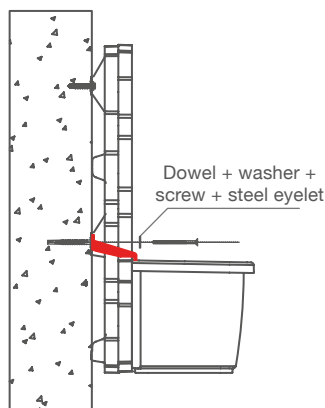
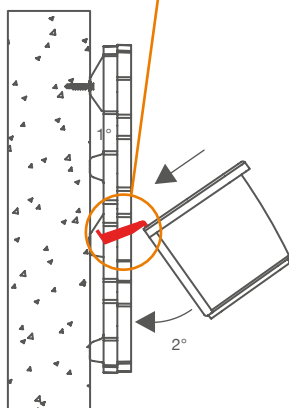

## WALL SUPPORT INSTALLATION

Wood



Concrete



Bricks



Coated cladding



You can install WALL-Y on existing walls or build self-supporting walls and partitions anchoring the elements to a substructure.

## SUB-STRUCTURE INSTALLATION

Timber

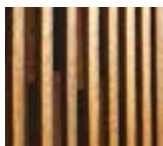

Aluminium



Profile



Frame



Geoplast provides technical support for the choice of the anchoring system, the specific type of support or for the creation of a structure suitable for every need.



## THE GREEN SOUL OF ARCHITECTURE

The use of vegetation to cover buildings and walls is now a standard in modern architecture. Like a thermal and acoustic insulation, vertical green walls protect the building from solar radiation, significantly improving its inhabitants' quality of life. WALL-Y can be installed quickly and easily, it resists to weathering and ensures the ideal habitat for the growth of plants. Thanks to WALL-Y, properties improve their energy performances and increase their aesthetic value.

THERMAL AND ACOUSTIC INSULATION

MICROCLIMATE

PROPERTY VALUE AND AESTHETIC





# VERTICAL GREEN WALLS

In Borgo Gasparina housing complex, with energy certification A, WALL-Y has been chosen to create vertical green walls in the two main facades facing the Garda lake. The elegant texture of WALL-Y grids guarantees a pleasant aesthetic effect even before the growth of the plants. In addition to “green” benefits, WALL-Y gave a personal character to the complex in a simple and fast way, ensuring at the same time thermal and acoustic protection to the walls.



# SEPARATION OF GARDENS AND BALCONIES

WALL-Y is a system adaptable to any specific requirement and does not need a wall to be installed. In case of fences between private places it can be coupled to a substructure to obtain selfsupporting dividers. The particular design of the trellis makes the shielding easier, creating a lightweight and pleasant structure.



# PLASTONELLA



**MODULAR SELF-INSTALL PLASTIC PAVER FOR OUTDOORS**

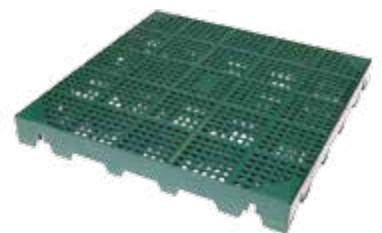



# PLASTONELLA THE SOLUTION

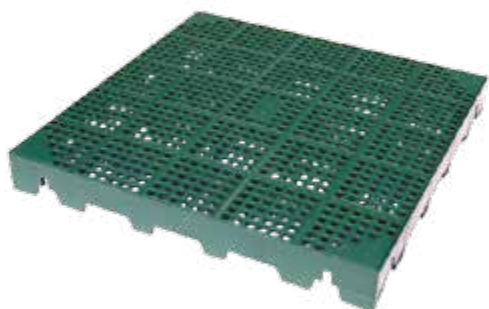

POOL EDGES



CONCERTS



SHOWERS



TERRACES



GARDEN



EVENTS



GENERAL TRACKS



CAMPING-SITES

PLASTONELLA is a modular perforated tile (5.400 holes/m<sup>2</sup>) that makes the flooring safe and dry to walk and to use in private areas.

## ADVANTAGES

- The perforated surface guarantees a perfect drainage of the water.
- Easy to install, without any hand tool.
- Protection of the waterproofings in walkable terraces.
- High versatility and adaptability to any surface.
- Quick installation thanks to the side-coupling and the bayonet coupling placed on the top.
- Self-cleaning from oils, solvents and chemical agents.
- Resistant to atmospheric agents and UV-rays.
- Combining the colours, a large range of drawings and geometrical shapes can be obtained.
- Easy to dismantle and to storage in damp locations.
- Safe surface there is no risk of slipping or falling.



# PLASTONELLA TECHNICAL DATA

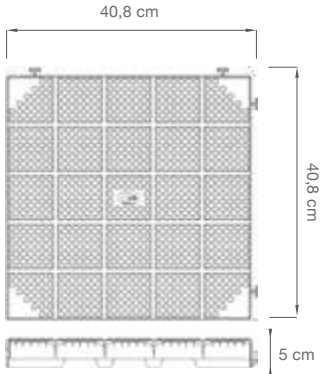

## PLASTONELLA

SIZE (cm)	40,8 x 40,8
HEIGHT h (cm)	5
Material	PP stable to UV rays
Load capability (t/m <sup>2</sup> )	3
Weight pc. (kg)	1,27
Packaging size (cm)	83 x 125 x 230
No. pcs.	270
m <sup>2</sup> per pallet	45
Color	Grey - Red - Green

## ON-SITE INSTALLATION

PLASTONELLA can be installed placing the tiles from left to right, from bottom to top, facing the couplings upwards and to the right.

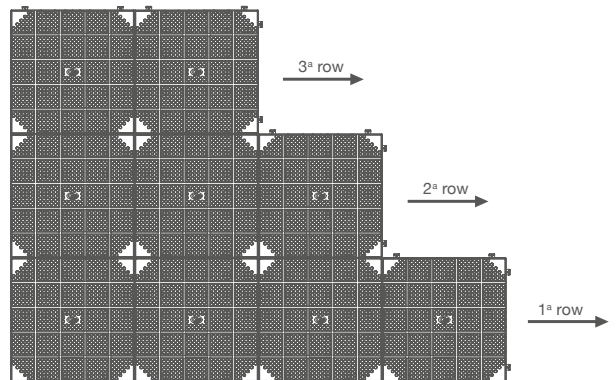
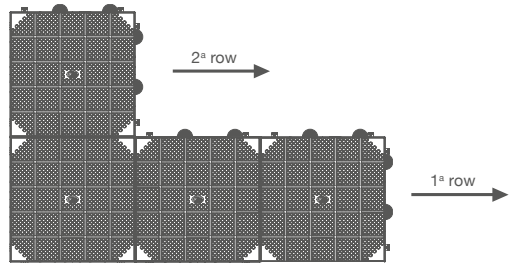
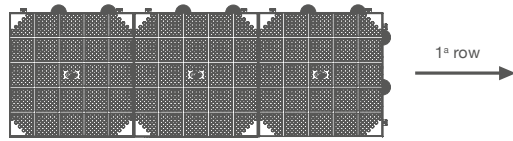

## ACCESSORIES - SUPPORTING FEET

The supporting feet should be used if the tile has to be placed in walkable terraces, in order to protect the waterproofing. PLASTONELLA needs 10 feet, 6 in the central part and 4 on the sides. The feet are characterized by a larger groove in order to connect both the tiles.



A) Two mutually perpendicular grooves. One larger than the other.



B) Round surface to place the sheath.

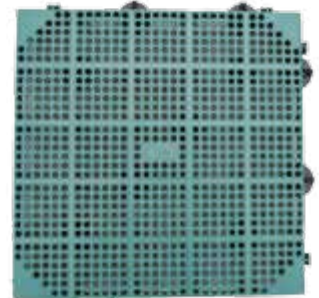
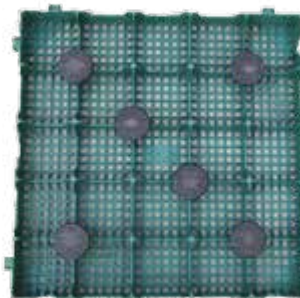



# TUBS AND WATER BUTTS



**HEAVY DUTY POTS AND TUBS  
FOR NURSERIES AND RAINWATER  
HARVESTING TANKS**





# TUBS

Tubs made of UV stable LD PE that maintain the 50% of the initial toughness for 350 KYLS. They are available with or without handles in different sizes and with or without drainage holes, in order to better adapt to all nurseries demands.



## TUBS WITH HANDLES



## TUBS WITHOUT HANDLES





# TUBS TECHNICAL DATA

## TUBS WITH HANDLES\*

ITEM	Diameter	Height (cm)	Pc. Pallet / Pile	Pallet Size	Color	Capacity (Liters)
MAS Ø 40	40	32	450 Pc. / Pallet	124 x 124 H 217	Black	30 lt.
MAS Ø 45	45	36	330 Pc. / Pallet	90 x 130 H 254	Black	40 lt.
MAS Ø 50 LOW	50	34	250 Pc. / Pallet	121 x 110 H 250	Black	43 lt.
MAS Ø 50 HIGH	50	39	250 Pc. / Pallet	110 x 125 H 250	Black	50 lt.
MAS Ø 55	55	43	160 Pc. / Pallet	112 x 115 H 234	Black	70 lt.
MAS Ø 60	60	46	160 Pc. / Pallet	118 x 118 H 240	Black	90 lt.
MAS Ø 65	65	46	140 Pc. / Pallet	127 x 127 H 228	Black	110 lt.
MAS Ø 70	70	50	105 Pc. / Pallet	144 x 125 H 246	Black	130 lt.
MAS Ø 75	75	51	60 Pc. / Pile	Ø 75 x H 253	Black	155 lt.
MAS Ø 80	80	51	60 Pc. / Pile	Ø 80,5 x H 258	Black	160 lt.

## TUBS WITHOUT HANDLES\*

ITEM	Diameter	Height (cm)	Pc. Pile	Pallet Size	Color	Capacity (Liters)
MAS 150 lt.	70	60	40 Pz.	Ø 69 x H 238	Black / Bordeaux	150 lt.
MAS 230 lt.	85	55	40 Pz.	Ø 89 x H 237	Black / Bordeaux	230 lt.
MAS 240 lt.	80	65	20 Pz.	Ø 77 x H 265	Black / Bordeaux	240 lt.
MAS 285 lt.	96	55	40 Pz.	Ø 95,5 x H 250	Black / Bordeaux	285 lt.
MAS 350 lt.	96	73	40 Pz.	Ø 94,5 x H 275	Black / Bordeaux	350 lt.
MAS 500 lt. HIGH	104	82	20 Pz.	Ø 103 x H 245	Black / Bordeaux	500 lt.
MAS 500 lt. LOW	118	68	40 Pz.	Ø 115 x H 220	Black / Bordeaux	500 lt.
MAS 600 lt.	120	68	25 Pz.	Ø 121,5 x H 253	Black / Bordeaux	600 lt.
MAS 750 lt.	122	82	16 Pz.	Ø 120 x H 256	Black / Bordeaux	750 lt.
MAS 1000 lt.	140	90	18 Pz.	Ø 135 x H 245	Black / Bordeaux	1000 lt.

\*Material and colors: the tubs with or without handles are made of low density polyethylene (LD PE) and are available in black and in bordeaux on request. The draining holes: all black tubs are available with or without holes, except MAS Ø40 e Ø45, which are produced with holes only. All bordeaux tubs are made without draining holes.

# DEMETRA

Demetra is a range of vases by Geoplast made in high density polyethylene, oriented to the private and agricultural field. They are light, functional and easy to handle; they resist to UV rays and to thermal expansions. The particular geometry of the base ensures an excellent drainage and avoids the roots spiral growth. Demetra vases are available in the black and terracotta versions. They are aesthetically pleasant and do not suffer weathers or microorganisms attacks.



## DEMETRA VASE



**30 lt.**



**35 lt.**



**55 lt.**



**70 lt.**



**90 lt.**

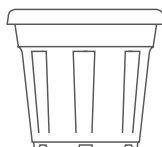

**110 lt.**

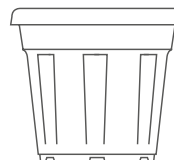

**130 lt.**

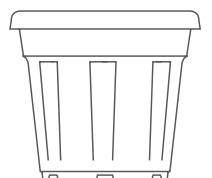



# DEMETRA ADVANTAGES

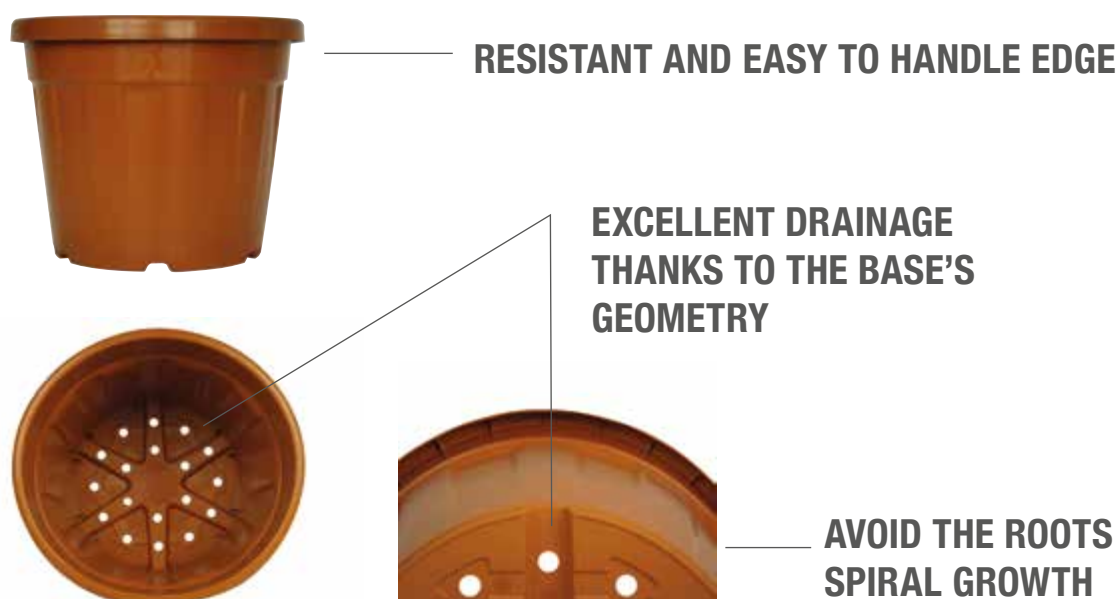

## DEMETRA TECHNICAL DATA\*

ITEM	External diameter	Internal diameter	Height (cm)	Draining surface (cm <sup>2</sup> )	Pc. Pallet	Pallet Size	Capacity (Liters)
DEM 30 lt.	40,5	37	33,5	30,48	540	125 x 125 H 230	30 lt.
DEM 35 lt.	44	40	35	40,64	330	80 x 120 H 230	35 lt.
DEM 55 lt.	51	46	40	45,72	230	100 x 130 H 230	55 lt.
DEM 70 lt.	56	51	43	45,72	180	110 x 110 H 225	70 lt.
DEM 90 lt.	60	55	47	50,80	180	120 x 120 H 225	90 lt.
DEM 110 lt.	66	61	48	60,96	160	130 x 130 H 225	110 lt.
DEM 130 lt.	68	64	50	60,96	135	135 x 120 H 240	130 lt.

\*HD PE: high density polyethylene, available in terracotta and black.

# WATER BUTTS

Water butts are a novelty inside Geoplast range: they are an economical and eco-friendly solution for rainwater recovery. They are made of high density polyethylene and are available in round, rectangular and square version with different capacities. Geoplast water butts are available green and charcoal grey and can be sold with or without raised base.



**ROUND**



**RECTANGULAR AND SQUARE**



## ROUND WATER BUTTS

Made of recycled plastics, strong and functional.

Available in the variations 210, 310 e 500 liters. Provided with a cap with a safety closure.



### OPENING AND CLOSURE OF THE CAP

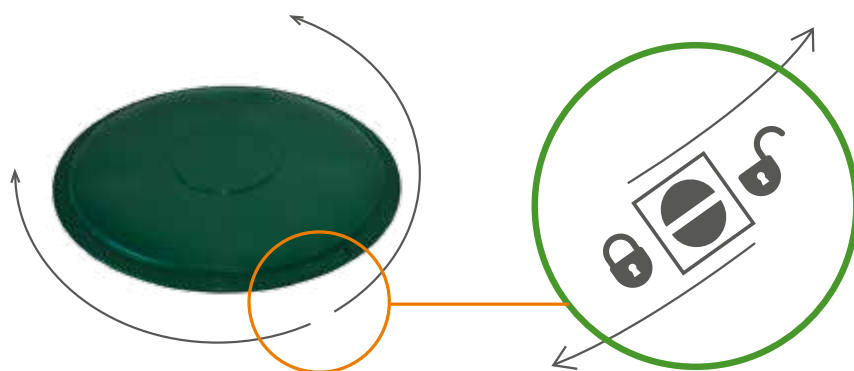

Rotate the cap towards right in order to unlock it and open it.

Rotate the cap towards left to lock it and close it.

### ROUND WATER BUTTS TECHNICAL DATA\*

Items	Color	Upper diameter	Height	Pallet Size Pcs. per Pallet	Capacity (liters)
Water butts 210	green charcoal grey	75 cm	73 cm	75x75xh252 cm pz. 52	210
Water butts 310	green charcoal grey	80 cm	90 cm	80x80xh250 cm pz. 40	310
Round BASE 210 and 310	green charcoal grey	58 cm	40 cm	75x120xh223 cm pz. 84	-
Water butts 500	green charcoal grey	104 cm	82 cm	100x100xh245 cm pz. 13	500

\*HD PE: high density polyethylene

# RECTANGULAR AND SQUARE WATER BUTTS

Element made of recycled plastic, strong and functional.  
Available in the variants 200 or 300 liters, with cap provided with safety closure.

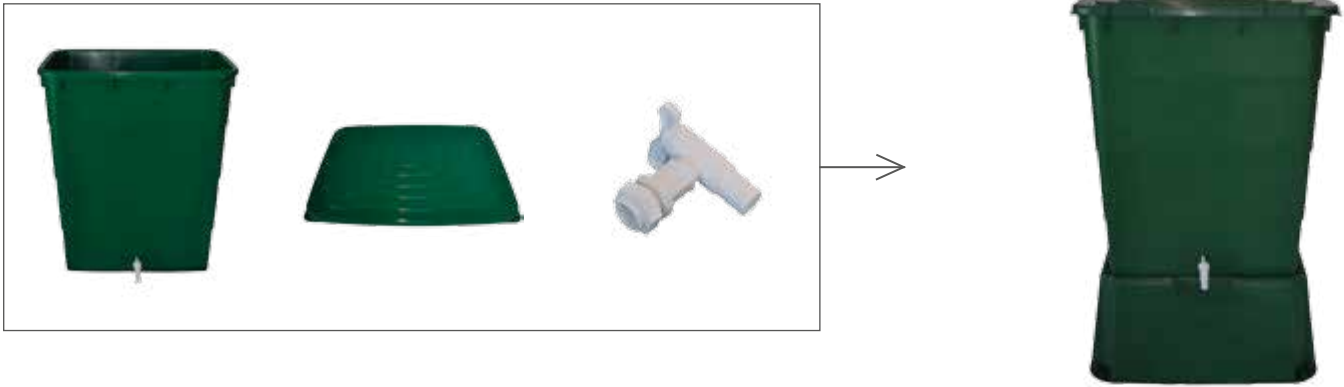

## OPENING AND CLOSURE OF THE CAP

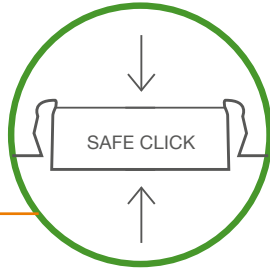
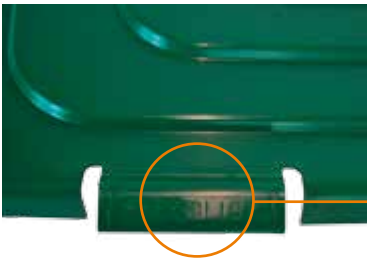

Pull downward to lock the safety closure of the cap.

Pull upwards to unlock the safety closure of the cap.

## WATER BUTTS TECHNICAL DATA\*

Items	Color	Sizes	Height	Pallet Size Pcs. per Pallet	Capacity (liters)
Water butt 200	green charcoal grey	60 x 60 cm	84 cm	80x120xh249 cm pz. 42	200
Water butt 300	green charcoal grey	60 x 80 cm	88 cm	80x120xh252 cm pz. 38	300
UNIKA universal base for all water butts	green charcoal grey	56 x 73 cm	33 cm	80x120xh250 cm pz. 146	-

\*HD PE: high density polyethylene



## SAFE CLICK

Geoplast water butts are provided with a child-proof safety locking system.

## 100% RECYCLABLE

High density polyethylene is plastic material entirely recyclable.





**Geoplast**  
Building beyond together

**Geoplast S.p.A.**

Via Martiri della Libertà, 6/8  
35010 Grantorto (PD) - Italy

Tel +39 049 9490289  
Fax +39 049 9494028

Geoplast@Geoplast.it

Geoplast.it



rev.003  
06/2017

